

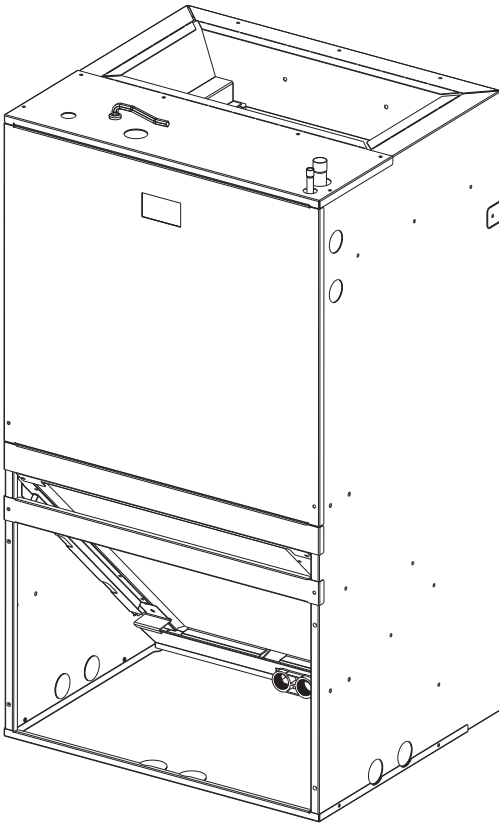

Installation Manual

WALL-MOUNT AIR HANDLERS 1.5 to 3 Ton

FAHC18HA15
FAHC24HA15
FAHC30HA15
FAHC36HA15



The manufacturer has a policy of continuous data improvement and it reserves the right to change design and specifications without notice.

All phases of this installation must comply with NATIONAL, STATE AND LOCAL CODES.

Important: This Document is customer property and is to remain with this unit.

Product Features

- Front or bottom return air.
- Blower slides out easily for maintenance.
- 2.5, 5, 7.5 and 10 kW single phase electric heaters.
- Painted finish on galvanized steel.
- Thermoplastic drain pan with bottom primary and secondary drain connections.
- 208/230 VAC operation.
- Stud or wall mounting installation.
- Direct-drive, multi-speed motor allows air volume variation for heating/cooling.
- Factory installed R410A orifice.
- Built-in filter rack.
- Wall-hanging brackets.
- Fully insulated cabinet.
- 3/4" NPT primary and secondary drains.
- AHRI certified and ETL listed.

Table of Contents

Safety Precaution	4
Dimension Data	6
Installation Instructions	9
Wiring.....	13
Electric Wiring Gauge	14
Performance Data.....	15

Section 1. Safety Precaution



WARNING

SAFETY HAZARD!

This information is intended for use by individuals possessing adequate backgrounds of electrical and mechanical experience. Any attempt to repair a central air conditioning product may result in personal injury and/or property damage. The manufacturer or seller cannot be responsible for the interpretation of this information, nor can it assume any liability in connection with its use.



WARNING

HAZARDOUS VOLTAGE!

Disconnect all electrical power, including remote disconnects before installing or servicing. Follow proper lockout/tagout procedures to ensure the power can not be inadvertently energized. Failure to disconnect power before servicing could result in death or serious injury.



WARNING

LIVE ELECTRICAL COMPONENTS!

During installation, testing, servicing, and troubleshooting of this product, it may be necessary to work with live electrical components. Failure to follow all electrical safety precautions when exposed to live electrical components could result in death or serious injury.



WARNING

EXPLOSION HAZARD!

Do not store corrosive or combustible materials, gasoline, or other flammable vapors or liquids near the unit. Failure to follow this warning could result in property damage, serious personal injury, or death.



WARNING

ELECTRICAL HAZARD!

Grounding Required! Follow proper local and state electrical code on requirements for grounding. Failure to follow this warning could result in property damage, serious personal injury, or death.



WARNING

HAZARDOUS VAPORS!

Do not install an air handler with a non-ducted return in the same closet, alcove, or utility room as a fossil fuel device. Hazardous vapors can be distributed throughout the conditioned space and equipment damage can result.

Important: These instructions do not cover all variations in systems nor provide for every possible contingency to be met in connection with the installation. Should further information be desired or should particular problems arise which are not covered sufficiently for the purchaser's purposes, the matter should be referred to your installing dealer or local distributor.

Important: Installation of this unit shall be made in accordance with the National Electric Code, NFPA No. 90A and 90B, and any other local codes or utilities requirements.

Note: The small air handlers have been evaluated in accordance with the Code of Federal Regulations, Chapter XX, Part 3280 or the equivalent. "SUITABLE FOR MOBILE HOME USE."



WARNING

PROPOSITION 65: This appliance contains fiberglass insulation. Respirable particles of fiberglass are known to State of California to cause cancer.

All manufacturer products meet current federal OSHA Guidelines for safety. California Proposition 65 warnings are required for certain products, which are not covered by the OSHA standards.

California's Proposition 65 requires warnings for products sold in California that contain or produce any of over 600 listed chemicals known to the State of California to cause cancer or birth defects such as fiberglass insulation, lead in brass, and combustion products from natural vapor.

All "new equipment" shipped for sale in California will have labels stating that the product contains and/or produces Proposition 65 chemicals. Although we have not changed our processes, having the same label on all our products facilitates manufacturing and shipping. We cannot always know "when, or if" products will be sold in the California market.

You may receive inquiries from customers about chemicals found in, or produced by, some of our heating and air-conditioning equipment, or found in natural vapor used with some of our products. Listed below are those chemicals and substances commonly associated with similar equipment in our industry and other manufacturers.

- Glass Wool (Fiberglass) Insulation
- Carbon Monoxide (CO)
- Formaldehyde
- Benzene

More details are available at the websites for OSHA (Occupational Safety and Health Administration), at www.osha.gov and the State of California's OEHHA (Office of Environmental Health Hazard Assessment), at www.oehha.org. Consumer education is important since the chemicals and substances on the list are found in our daily lives. Most consumers are aware that products present safety and health risks, when improperly used, handled and maintained.



CAUTION

CORROSION HAZARD!

To prevent shortening its service life, the air handler should not be used during the finishing phases of construction. The low return air temperatures can lead to the formation of condensate. Condensate in the presence of chlorides and fluorides from paint, varnish, stains, adhesives, cleaning compounds, and cement creates a corrosive condition which may cause rapid deterioration of the cabinet and internal components.



CAUTION

SAFETY HAZARD!

Sharp Edge Hazard. Be careful of sharp edges on equipment or any cuts made on sheet metal while installing or servicing. Personal injury may result.



WARNING

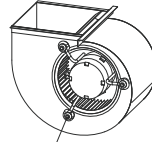

BLOWER MOT. OR
SHIPPING BOLT

Make sure the blower motor support is tight (3-motor mount bolts) then check to see if wheel is secured to motor shaft before operating unit.

Section 2. Dimension Data

2.1 Unit Dimensions

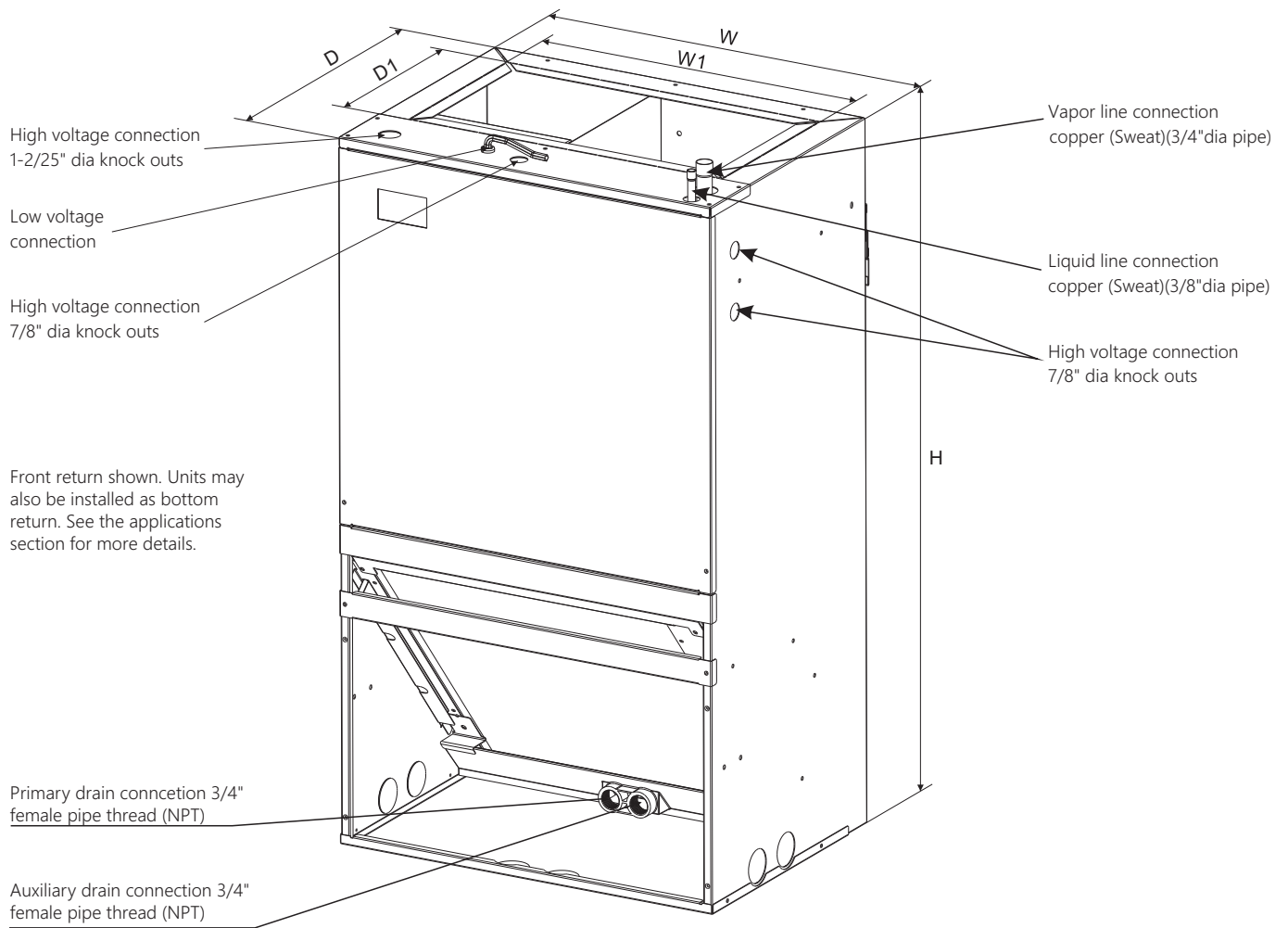

All units are configured for vertical upflow.
Units cannot be installed in any other configuration.

Model	Dimensions- In. (mm)					Unit Weight / Shipping Weight Lbs. (kg)
	Height H	Width W	Width W1	Depth D	Depth D1	
18K	36 (915)	20-1/2 (522)	17-2/5 (442)	15 (381)	9-3/5 (244)	88 / 99 (40 / 45)
24K	36 (915)	20-1/2 (522)	17-2/5 (442)	15 (381)	9-3/5 (244)	88 / 99 (40 / 45)

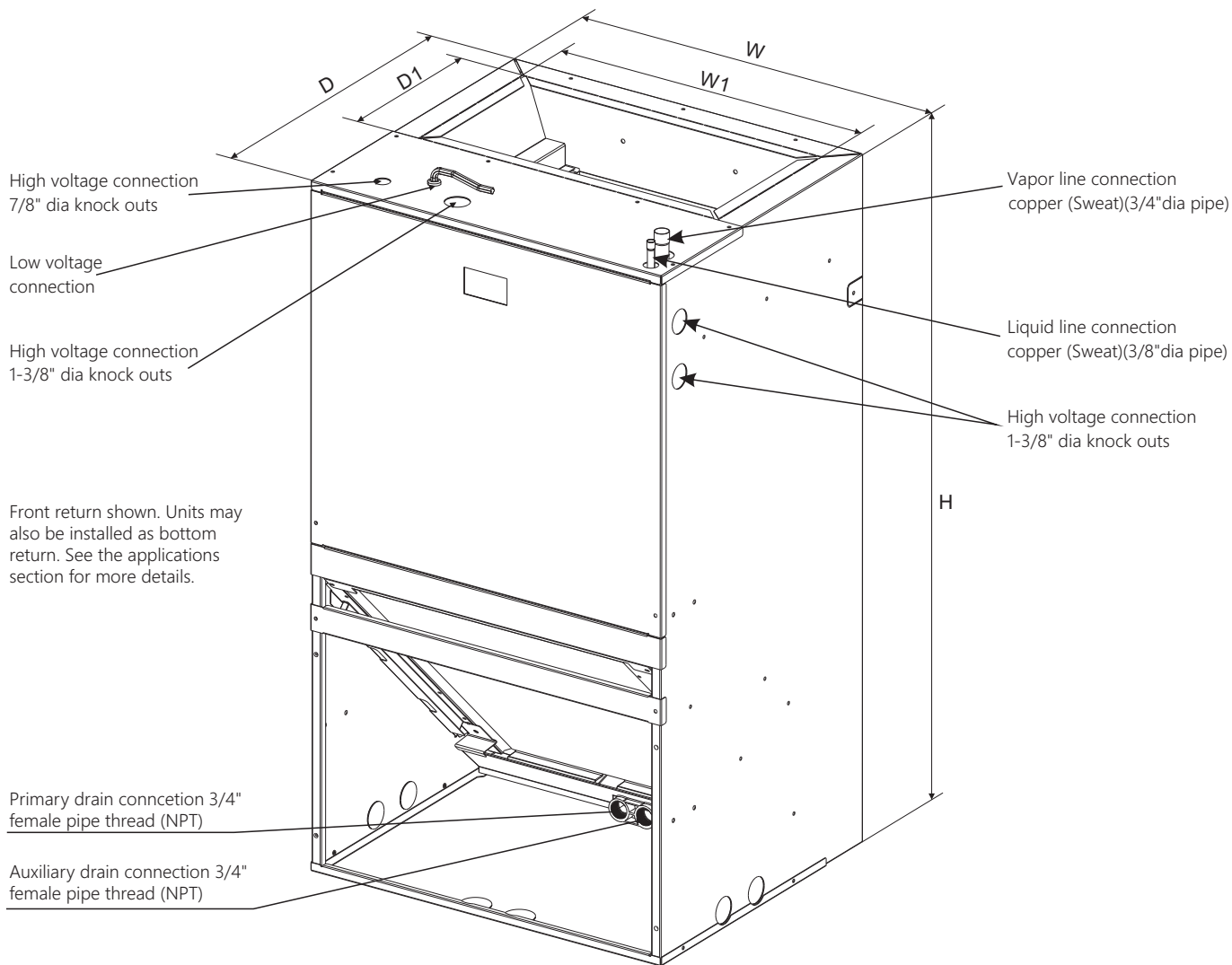

All units are configured for vertical upflow.
Units cannot be installed in any other configuration.

Model	Dimensions- In. (mm)					Unit Weight / Shipping Weight Lbs. (kg)
	Height H	Width W	Width W1	Depth D	Depth D1	
30K	39-3/5 (1006)	22 (559)	18-4/5 (477)	19 (485)	10 (251)	110/ 121 (50 / 55)
36K	39-3/5 (1006)	22 (559)	18-4/5 (477)	19 (485)	10 (251)	110/ 121 (50 / 55)

2.2 Unit Back Dimensions

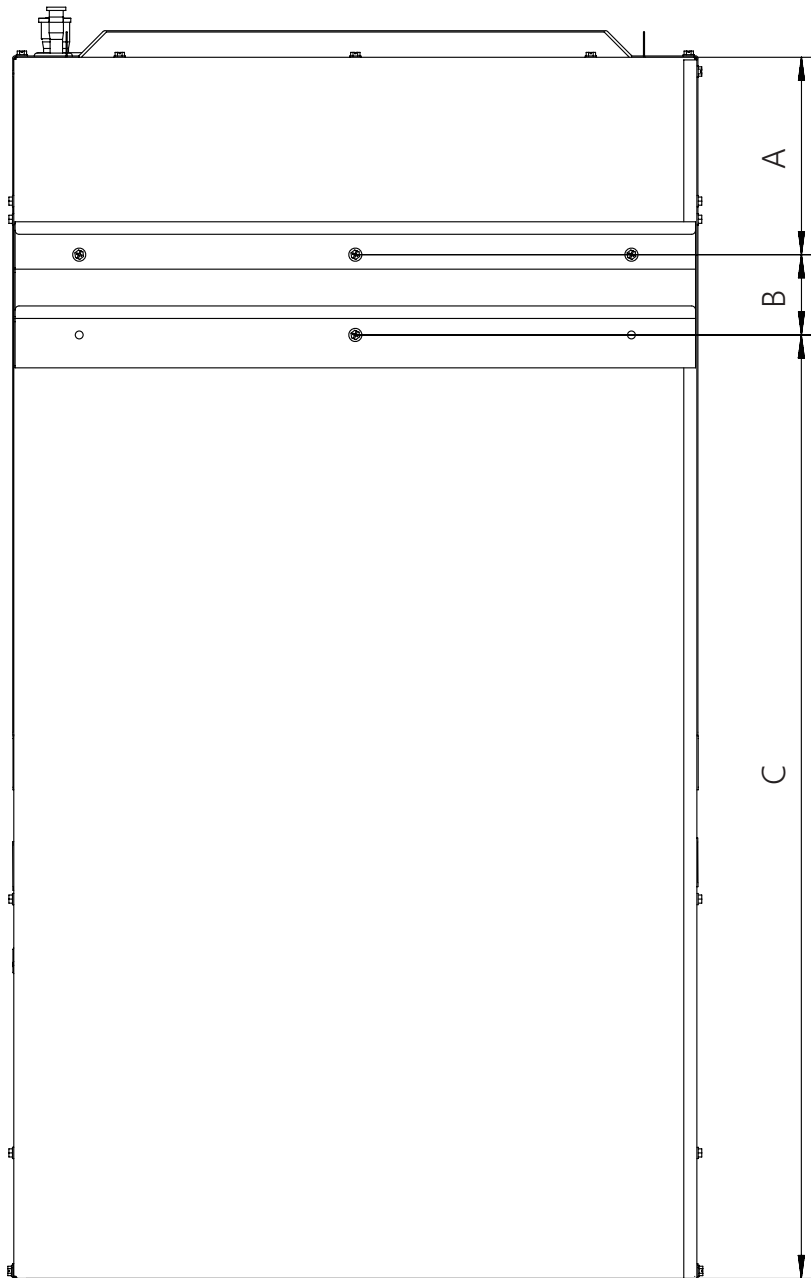

Model	Dimensions- In. (mm)		
	A	B	C
18K	5-3/8 (136)	2-2/5 (61)	28-1/4 (718)
24K	5-3/8 (136)	2-2/5 (61)	28-1/4 (718)
30K	6 (151)	2-2/5 (61)	31-1/4 (794)
36K	6 (151)	2-2/5 (61)	31-1/4 (794)

Section 3. Installation Instructions

3.1 Unpacking

Unpack unit and move to final location. Remove carton, taking care not to damage unit. Remove protective sheet metal from the base of the unit, if equipped. Inspect equipment for damage prior to installation. File claim with shipping company if shipment is damaged or incomplete. Locate rating plate on unit. It contains information needed to properly install unit. Check rating plate to be sure unit matches job specifications. A front access panel is provided, which permits access to blower assembly and electrical controls for removal and servicing.

3.2 Location

The small air handler should be centrally located and may be installed in a closet, alcove, utility room, or basement. Minimum clearances must be met.

The air handler comes standard with two different options for mounting, wall mount or frame mount. Both mounting options require the unit to be level from side to side and from front to back in order to allow condensate to properly drain from the unit. Failure to do this will result in condensate leaking out from the unit, potentially causing structural damage to the surrounding support structures, dry wall, carpet, etc. Also, both mounting structures require the ability to accommodate a minimum of 150 lb load. Failure to do this will cause damage to the support structure and potentially damage the unit.

3.2.1 Wall Mount

The air handler comes standard with a wall mounting bracket and air handler mounting bracket. Reference Figure 3-1 for more details.

1. Remove lower wall mounting bracket from the back of the unit by removing one screw which attaches the bracket to the air handler. Note: Discard the screw after you have removed the wall mounting bracket.
2. Install bracket on the wall by using 3 wood screws (not provided). Make sure the bracket is level in order to provided proper drainage from the unit. Note: Do not attach the wall mounting bracket into unsupported dry wall. Make sure that the wood screws are going into a structure that can support a minimum load of 150 lb.
3. Lift the air handler above the wall mounting bracket and attach the unit to the installed bracket. Reference Figure 3-1.
4. Install the additional bottom plate for extra support for this type mounting (see figure 3-1).

Note: The additional plate is shipped in the bottom of the shipping carton.

3.2.2 Frame Mount

The air handler comes with 8 clearance holes (4 on each side). These holes are used to mount the air handler inside of a frame structure (see Figure 3-2). When mounting in this fashion, make sure that the wood screws are mounted from within the air handler and not from outside the unit in order to avoid damaging the coil. If the frame does not provide support in the front of the unit and additional support is needed, open up the tabs and fix the unit to the frame or other support structure with screws. Select a solid and level site to ensure proper installation of the frame mount. Verify that there is sufficient space for installation and maintenance.(see Figure. 3-3)

IMPORTANT: The (8) wood screws are not provided with the unit. #12 x 1 1/2" wood screws are recommended. When the unit is installed on a wood frame, the screws should be used to fix the unit to the studs. If they are not used, the unit may fall down or cause other damage. See Figure 3-2 for frame mount installation.

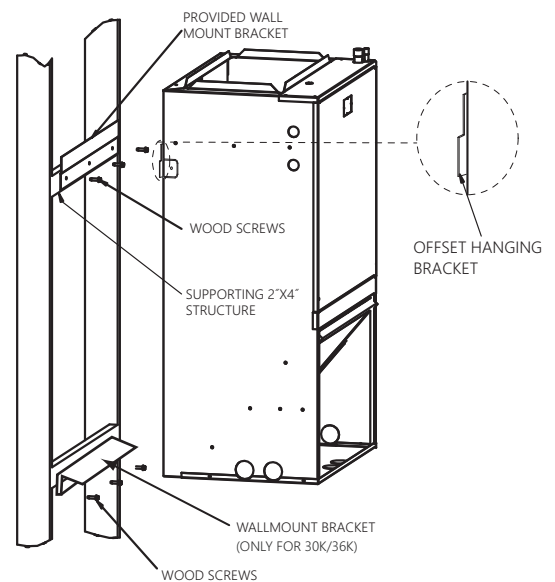
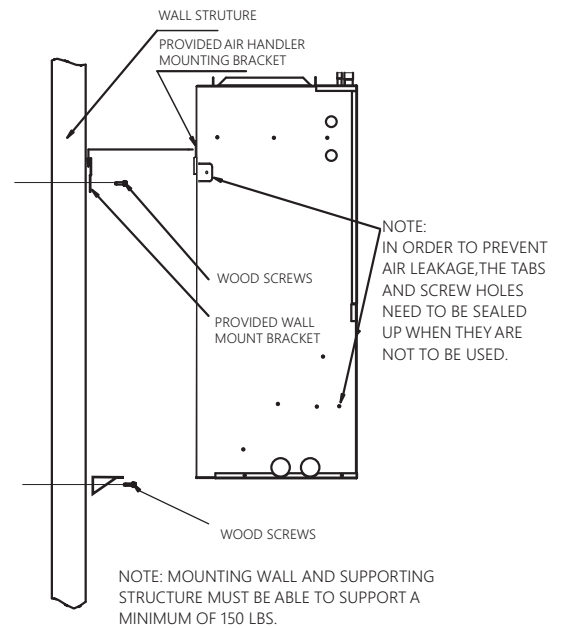

Fig. 3-1 Wall Mount

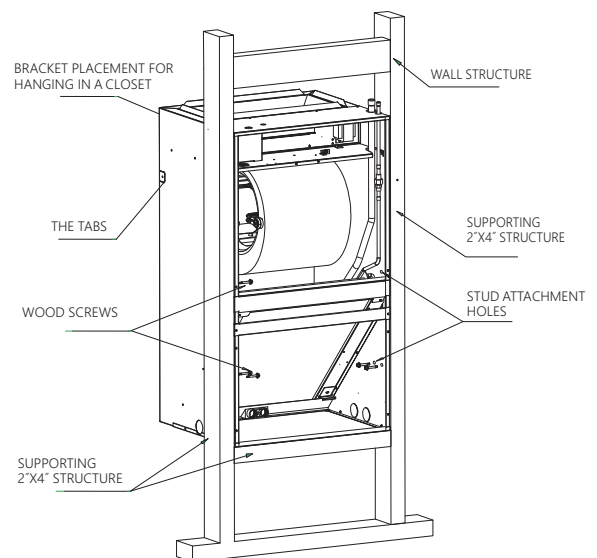

Fig. 3-2 Frame Mount

3.3 Duct Work

Field ductwork must comply with the National Fire Protection Association NFPA 90A, NFPA 90B and any applicable local ordinance.

WARNING

Do not, under any circumstances, connect return ductwork to any other heat producing device such as fireplace insert, stove, etc. Unauthorized use of such devices may result in fire, carbon monoxide poisoning, explosion, personal injury or property damage.

Sheet metal ductwork run in unconditioned spaces must be insulated and covered with a vapor barrier. Fibrous ductwork may be used if constructed and installed in accordance with SMACNA Construction Standard on Fibrous Glass Ducts. Ductwork must comply with National Fire Protection Association as tested by U/L Standard 181 for Class I Air Ducts. Check local codes for requirements on ductwork and insulation.

- Duct system must be designed within the range of external static pressure the unit is designed to operate against. It is important that the system airflow be adequate. Make sure supply and return ductwork, grilles, special filters, accessories, etc. are accounted for in total resistance. See airflow performance tables in this manual.
- Design the duct system in accordance with "ACCA" Manual "O" Design for Residential Winter and Summer Air Conditioning and Equipment Selection. Latest editions are available from: "ACCA" Air Conditioning Contractors of America. If duct system incorporates flexible air duct, be sure pressure drop information (straight length plus all turns) shown in "ACCA" Manual "D" is accounted for in system.
- Supply plenum is attached to the 3/4" duct flanges supplied with the unit.
- **IMPORTANT:** If an elbow is included in the plenum close to the unit, it must not be smaller than the dimensions of the supply duct flange on the unit.
- **IMPORTANT:** If connected to the blower casing, the front flange on the return duct must not be screwed into the area where the power wiring is located. Drills or sharp screw points can damage insulation on wires located inside unit.
- Secure the supply and return ductwork to the unit flanges, using proper fasteners for the type of duct used and tape the duct-to-unit joint as required to prevent air leaks.

3.4 Condensate Drain

The unit is supplied with primary and auxiliary condensate drains that have 3/4" NPT connections. Both drains must be trapped outside the unit and piped in accordance with applicable materials and building codes. Do not reduce the drain line size less than the connection size on the drain pan. Condensate should be piped to an open drain or to the outside. All drains must pitch downward away from the unit a minimum of 1/4" per foot of line to ensure proper drainage. Insulate the primary drain line to prevent sweating where dew point temperatures may be met. (Insulation is optional depending on climate and application needs.)

Important: If cleanout Tee is used, standpipe must be sealed/capped.

WARNING

Supply duct is intended to handle conditioned air for circulation through a duct supplying only one room. Room space may be partitioned into rooms within the same unit, but supply air is not to be delivered to any other rooms.

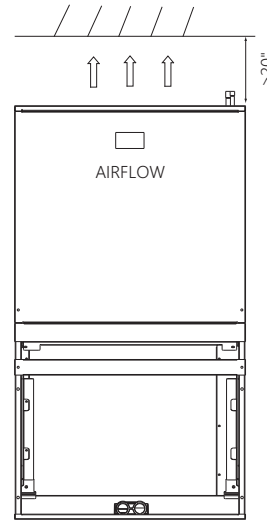

Top view of the indoor unit clearance (including air duct).

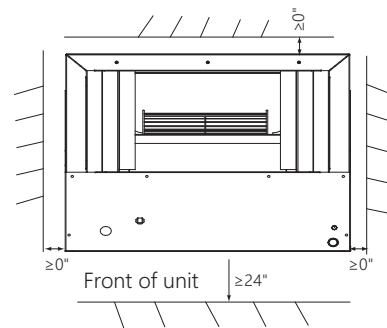

Fig.3-3 Space for Frame Mount

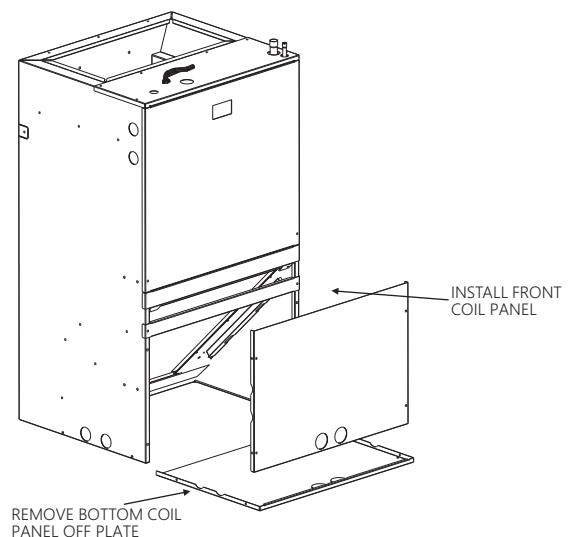

Fig. 3-4 Different Air Supply

Remove the cross brace when converting cabinet to bottom return.

3.5 Refrigerant Piping

Refrigerant pipe connections are located on the top of the unit. Refrigerant piping external to the unit shall be sized in accordance with the instructions of the outdoor equipment. When units are recessed mounted in the wall, make certain that piping connections are pressure tested prior to the wall being closed. While brazing, be sure to protect the cabinet and grommets from heat damage.

3.6 Metering Device

All units are shipped and installed with an orifice designed for air conditioning or heat pump operation. Pressures equalize after shut down. Some outdoor models may require a start assist kit. See outdoor unit for more information.

3.7 Blower

This unit is supplied with a multi-speed motor with a direct drive blower wheel which can obtain various air flows. The unit is shipped with factory set cooling and heating speed taps. Airflow performance tables are available for additional speed taps. Disconnect all power to the unit before making any adjustments to the motor speed taps. Be sure to check the air flow and the temperature drop across the evaporator coil to ensure sufficient air flow.

3.8 Wiring

Field wiring must comply with the National Electric Code (C.E.C. in Canada) and any applicable local ordinance.

WARNING

Disconnect all power to unit before installing or servicing. More than one disconnect switch may be required to de-energize the equipment. Hazardous voltage can cause severe personal injury or death.

3.8.1 Power Wiring

It is important that proper electrical power is available for connection to the unit model being installed. See the unit nameplate, wiring diagram and electrical data in the installation instructions.

- If required, install a branch circuit disconnect of adequate size, located within sight of, and readily accessible to the unit.
- **IMPORTANT:** After the Electric Heater is installed, units are equipped with one 60 amp. circuit breaker. These breaker(s) protect the internal wiring in the event of a short circuit and serve as a disconnect. Circuit breakers installed within the unit do not provide over-current protection of the supply wiring and therefore may be sized larger than the branch circuit protection.
- Supply circuit power wiring must be 75°C minimum copper conductors only. See Electrical Data in this section for ampacity, wire size and circuit protector requirements. Supply circuit protective devices may be either fuses or "HACR" type circuit breakers.
- Power wiring may be connected to either the right or left side. Two 7/8" dia. concentric knockouts are provided for connection of power wiring to unit.
- Power wiring is connected to the power cable in unit electric cabinet.

3.8.2 Control Wiring

IMPORTANT: Class 2 low voltage control wiring should not be run in conduit with main power wiring and must be separated from power wiring, unless class 1 wire of proper voltage rating is used.

- Low voltage control wiring should be 18 AWG. color-coded. For lengths longer than 100 ft., 16 AWG. wire should be used.

- Low voltage control connections are made to low voltage pigtailed extending from top of air handler. Connections for control wiring are made with wire nuts. Control wiring knockouts (7/8") are also provided on the right and left side of the unit for side connection.

- See wiring diagrams attached to indoor and outdoor sections to be connected.

- Make sure, after installation, separation of control wiring and power wiring has been maintained.

3.8.3 Grounding

WARNING

The unit must be permanently grounded. Failure to do so can result in electrical shock causing personal injury or death.

- Grounding may be accomplished when installed in accordance with electrical codes by bonding the metal conduit to the unit cabinet or by attaching ground wire(s) to ground lug(s) provided in the unit wiring compartment.

- Ground lug(s) are located close to wire entrance on left side of unit (upflow). Lug(s) may be moved to marked locations near wire entrance on right side of unit (upflow) if alternate location is more convenient.

- Use of multiple supply circuits require grounding of each circuit to lug(s) provided in unit.

3.8.4 Electrical Data

MODEL	VOLTAGE	HERTZS	HP	RPM	SPEEDS	CIRCUIT AMPS.	MAXIMUM CIRCUIT PROTECTOR
18K	208/230	60	1/3	960	5	1.9	3(A)
24K	208/230	60	1/3	1010	5	2.2	3(A)
30K	208/230	60	1/2	960	5	2.6	3(A)
36K	208/230	60	1/2	1000	5	3.2	6(A)

3.9 Air Filter

An air filter must be installed before air enters the evaporator coil in order to protect the coil, blower, and other internal parts from excessive dirt and dust . A filter must be installed. Consult the filter manufacturer for proper sizing and maximum velocity requirements.

Filter Sizes

Model	Filter Sizes in. [mm]
18K/24K	15*19 [381*483]
30K/36K	20*20 [508*508]

3.10 Thermostat

Select a thermostat that is commonly used with HP or AC single stage heating/cooling with electric heat. The thermostat will energize the fan on a demand for heating or cooling.

Install the thermostat on an inside wall, away from drafts, lights or other heat sources in a location that has sufficient air circulation from other rooms being controlled by the thermostat. The thermostat should be mounted 4 to 5 feet above the floor.

3.11 Sequence of Operation

Cooling (cooling only)

Constant torque version – When the thermostat calls for cooling, the circuit from R to G is completed. The blower motor is energized directly by the 24VAC signal from the thermostat.

The circuit from R to Y is also completed, energizing the compressor contactor of the outdoor unit. The contactor will close and start the compressor and condenser fan motor.

Cooling (heat pump)

Constant torque version – When the thermostat calls for cooling, the circuit from R to G is completed. The blower motor is energized directly by the 24VAC signal from the thermostat.

The circuit from R to Y is also completed, energizing the compressor contactor of the outdoor unit. The contactor will close and start the compressor and condenser fan motor.

Heating (heat pump)

Constant torque version – When the thermostat calls for heating, the circuit from R to G is completed and the blower motor is energized directly by the 24VAC signal from the thermostat.

The circuit from R to Y is also completed, energizing the compressor contactor of the outdoor unit. The contactor will close and start the compressor and condenser fan motor.

Circuit R to B energizes the reversing valve to the heating position.

If the indoor temperature continues to fall, the R to W2 circuit is completed, energizing the electric heat contactor(s).

Heating (electric heat only)

Note: The thermostat must be setup to bring the blower on when the electric heat is energized.

Constant torque version - When the thermostat calls for heating, the circuit from R to G is completed and the blower motor is energized directly by the 24VAC signal from the thermostat. The circuit from R to W1 is completed energizing the heating contactor(s).

If the indoor temperature continues to fall, the R to W2 circuit is completed, energizing the electric heat contactor(s).

Defrost

Supplemental heat during defrost can be provided by connecting the W1 (white) wire from the outdoor unit to W1 at the indoor unit. This will prevent cold air from being discharged from the indoor unit during defrost.

Low voltage control wiring should be 18 AWG, color coded (105 degree C minimum). For lengths longer than 100ft., 16 AWG wire should be used. Make certain that separation of control wiring and power wiring has been maintained.

3.12 Operational And Checkout Procedures

To obtain proper performance, all units must be operated and charge adjustments made in accordance with procedures found in the Service Facts document of the outdoor unit.

After installation has been completed, it is recommended that the entire system be checked against the following list:

1. Be sure unit suspension (if used) is secure and there are no tools or loose debris in, around or on top of the unit.
2. Properly insulate suction lines and fittings.
3. Properly secure and isolate all refrigerant lines.
4. Verify that all electrical connections are tight.
5. Check all duct outlets; they must be open and unrestricted.
6. Check drain lines and be sure all joints are tight.
7. Be sure the return air filter is installed.
8. Operate complete system in each mode to verify proper performance. Verify operation of supplementary electric heater.

3.13 Maintenance

The system air filter(s) should be inspected, cleaned or replaced at least monthly. Make certain that the access panels are replaced and secured properly before placing the unit back in operation. This product is designed for dependable service; however, periodic maintenance should be scheduled and conducted by trained professional service personnel. This service should be conducted at least annually, and should include testing and inspection of electrical and refrigerant components. The heat transfer surface should be cleaned. The blower motor is permanently lubricated for normal operating conditions.

Section 4. Wiring

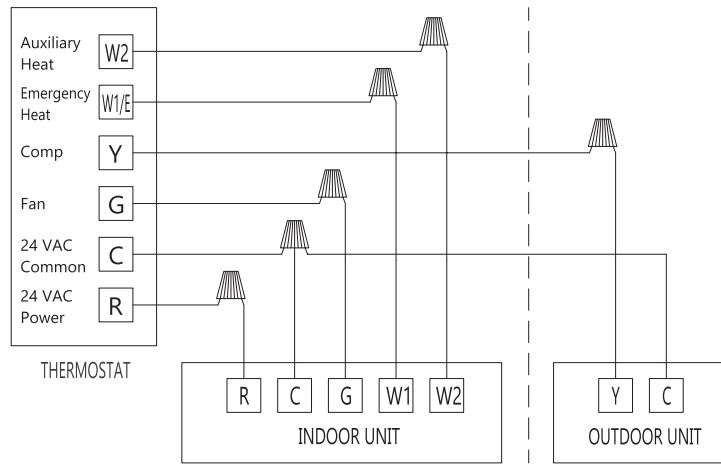

Wiring connection for A/C Systems

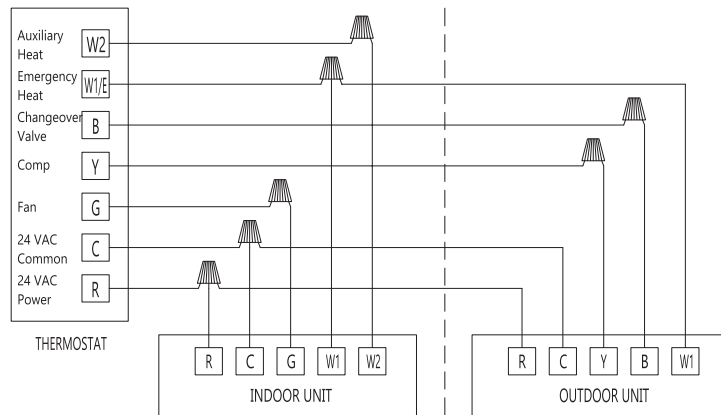

Wiring connection for H/P Systems

Applicable to 18K/24K/30K/36K

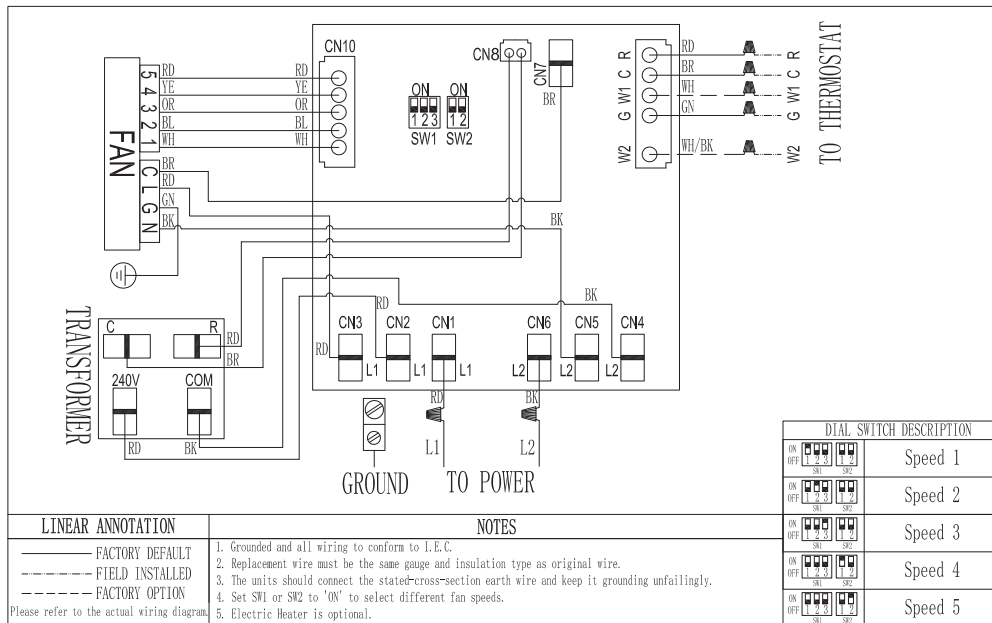

DIP Switch	Fan Speed	Model	DIP Switch	Fan Speed	Model
ON OFF	Speed 2	18K	ON OFF	Speed 4	36K
ON OFF	Speed 3	24K、30K	ON OFF	Speed 5	/

Section 5. Electric Wiring Gauge

Note:

The cross-section areas of wires or lines should not be less than the corresponding ones listed in the table below; Besides, if the power wires is quite long from the unit, please choose the windings with larger cross-section area to guarantee the normal power supply.

Model (cooling only type)			18K	24K	30K	36K
Line Gauge	Indoor Unit Power Line	Line Quantity	3	3	3	3
		Line Diameter(AWG)	16	16	16	16
	Outdoor Unit Power Line	Line Quantity	3	3	3	3
		Line Diameter(AWG)	14	14	12	12
	Indoor-Thermostat Singal Line	Line Quantity	5	5	5	5
		Line Diameter(AWG)	18	18	18	18
	Outdoor-Thermostat Singal Line	Line Quantity	2	2	2	2
		Line Diameter(AWG)	18	18	18	18

Model (cooling & heating type)			18K	24K	30K	36K
Line Gauge	Indoor Unit Power Line	Line Quantity	3	3	3	3
		Line Diameter(AWG)	16	16	16	16
	Outdoor Unit Power Line	Line Quantity	3	3	3	3
		Line Diameter(AWG)	14	14	12	12
	Indoor-Thermostat Singal Line	Line Quantity	5	5	5	5
		Line Diameter(AWG)	18	18	18	18
	Outdoor-Thermostat Singal Line	Line Quantity	5	5	5	5
		Line Diameter(AWG)	18	18	18	18

Section 6. Performance Data

Airflow performance data is based on cooling performance with a coil and no filter in place. Select performance table for appropriate unit size external static applied to unit allows operation within the minimum and maximum limits shown in table below for both cooling and electric heat operation.

Airflow Performance (Standard CFM)

Model	Blower Speeds	External Static Pressure(in.w.c)								
		0	0.1	0.2	0.3	0.4	0.5	0.6	0.7	0.8
18K	1	812	783	741	698	669	619	586	525	474
	2-Factory Default	916	875	851	812	786	746	717	673	634
	3	1005	978	941	917	882	856	819	792	752
	4									
	5									
24K	1	812	783	741	698	669	619	586	525	474
	2	916	875	851	812	786	746	717	673	634
	3-Factory Default	1005	978	941	917	882	856	819	792	752
	4									
	5									
30K	1	1059	1009	960	921	871	829	751	692	616
	2	1150	1116	1069	1036	988	953	912	850	779
	3-Factory Default	1282	1235	1203	1158	1131	1076	1050	1015	953
	4	1404	1374	1335	1306	1265	1231	1195	1150	1115
	5	1575	1534	1492	1446	1401	1331	1239	1132	1025
36K	1	1059	1009	960	921	871	829	751	692	616
	2	1150	1116	1069	1036	988	953	912	850	779
	3	1282	1235	1203	1158	1131	1076	1050	1015	953
	4-Factory Default	1404	1374	1335	1306	1265	1231	1195	1150	1115
	5	1575	1534	1492	1446	1401	1331	1239	1132	1025

NOTES:

1. Airflow based upon dry coil at 230V with no electric heat and no filter. For 18, 24, 30 and 36 sizes, airflow at 208V is approximately the same as 230V because the multi-tap ECM motor is a constant torque motor. The torque doesn't drop off at the speeds in which the motor operates.
2. Airflow is equivalent for front or bottom return configurations.

The air distribution system has the greatest effect on airflow. The duct system is totally controlled by the contractor. For this reason, the contractor should use only industry-recognized procedures.

Heat pump systems require a specified airflow. Each ton of cooling requires between 350 and 450 cubic feet of air per minute (CFM), or 400 CFM nominally.

Duct design and construction should be carefully done. System performance can be lowered dramatically through bad planning or workmanship. Air supply diffusers must be selected and located carefully. They must be sized and positioned to deliver air along the perimeter of the space. If they are too small for their intended airflow, they become noisy. If they are not located properly, they cause drafts. Air grilles must be properly sized to carry air back to the blower. If they are too small, they also cause noise.

The installers should balance the air distribution system to ensure proper quiet airflow to all rooms in the home. This ensures a comfortable living space.

