

Exploded View - FAHC30HA15

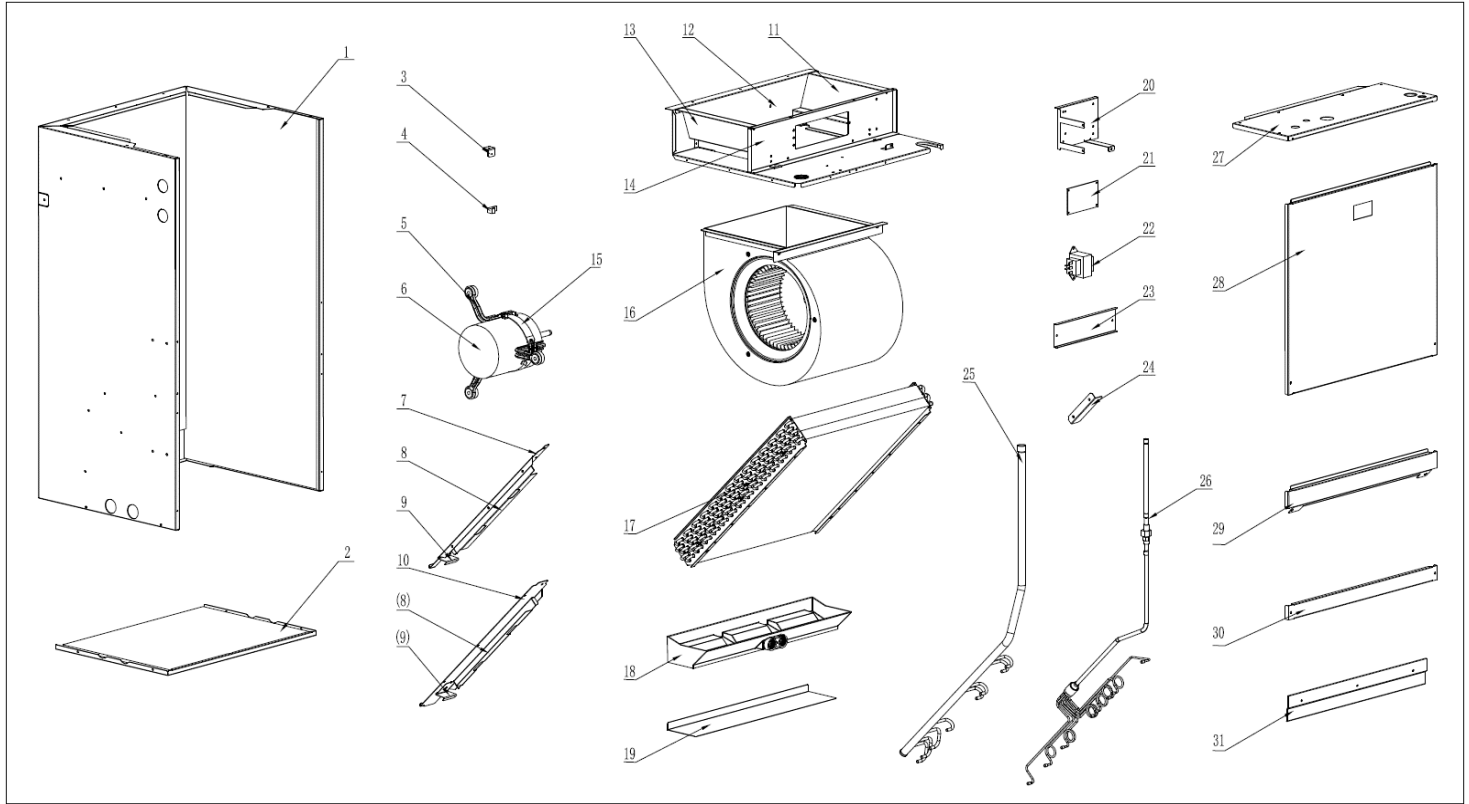

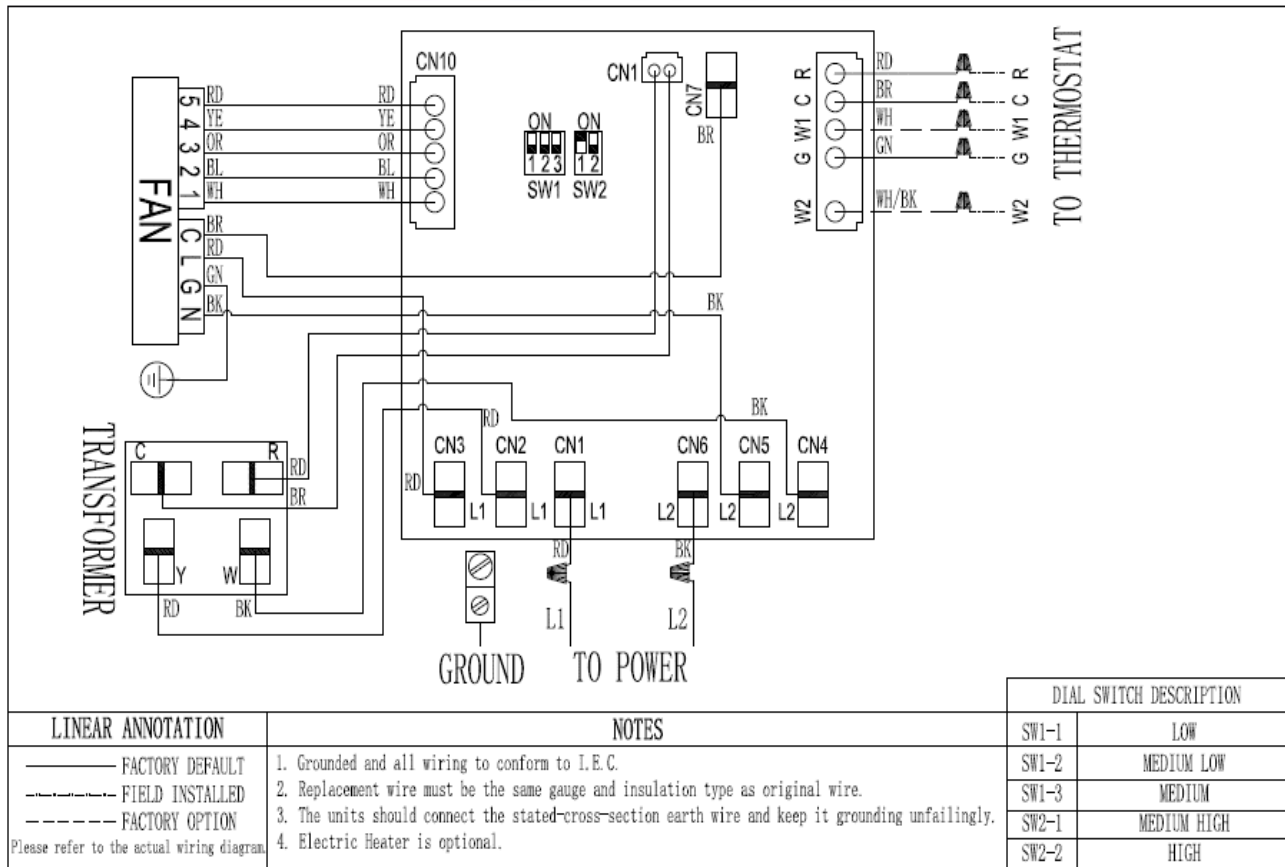

No.	Part Name	Quantity	Price(\$)	BOM Code	Remark
1	Base pan cotton sticking assembly	1		91044982	63.14
2	Lower side panel cotton sticking assembly	1		91044995	1.54
3	Wind wheel mounting block	2		91043690	8.63
4	Brass binding post	1		91043061	1.16
5	Motor fixing beam assembly	3		91043693	1.32
6	Fan motor	1		91044855	241.26
7	Evaporator left connecting plate	1		91044988	0.83
8	Filter rail	2		91044990	0.85
9	Drain pan fixing block	2		91044874	0.24
10	Evaporator right connecting plate	1		91044989	1.54
11	Right side panel of air duct	1		91044985	2.33
12	Volute fixing plate	1		91044983	10.01
13	Left side panel of air duct	1		91044984	2.33
14	Front side panel of air duct	1		91044986	3.08
15	Motor clamp	1		91043692	0.80
16	Wind wheel volute	1		91038108	69.60
17	Evaporator	1		91044428	182.96
18	Plastic drain pan cotton sticking assembly	1		91044420	8.44
19	Drain pan support plate	1		91044987	1.78
20	Electric control mounting plate	1		91044999	0.74
21	PCB	1		91034032	5.29
22	Transformer	1		91041237	14.66
23	Electric heater sealing plate	1		91043691	1.73
24	Limit plate	1		91044870	0.53
25	Evaporator gas collector pipe assembly	1		91044762	18.61
26	Evaporator shunt pipe assembly	1		91044761	24.74
27	Electric control cover cotton sticking assembly	1		91044991	6.01
28	Upper side panel cotton sticking assembly	1		91044992	16.55
29	Sealing plate cotton sticking assembly	1		91044993	2.77
30	Lower reinforcement plate	1		91044994	1.57
31	Rear mounting plate	2		91044881	1.9