

Exploded View CAC6013H18

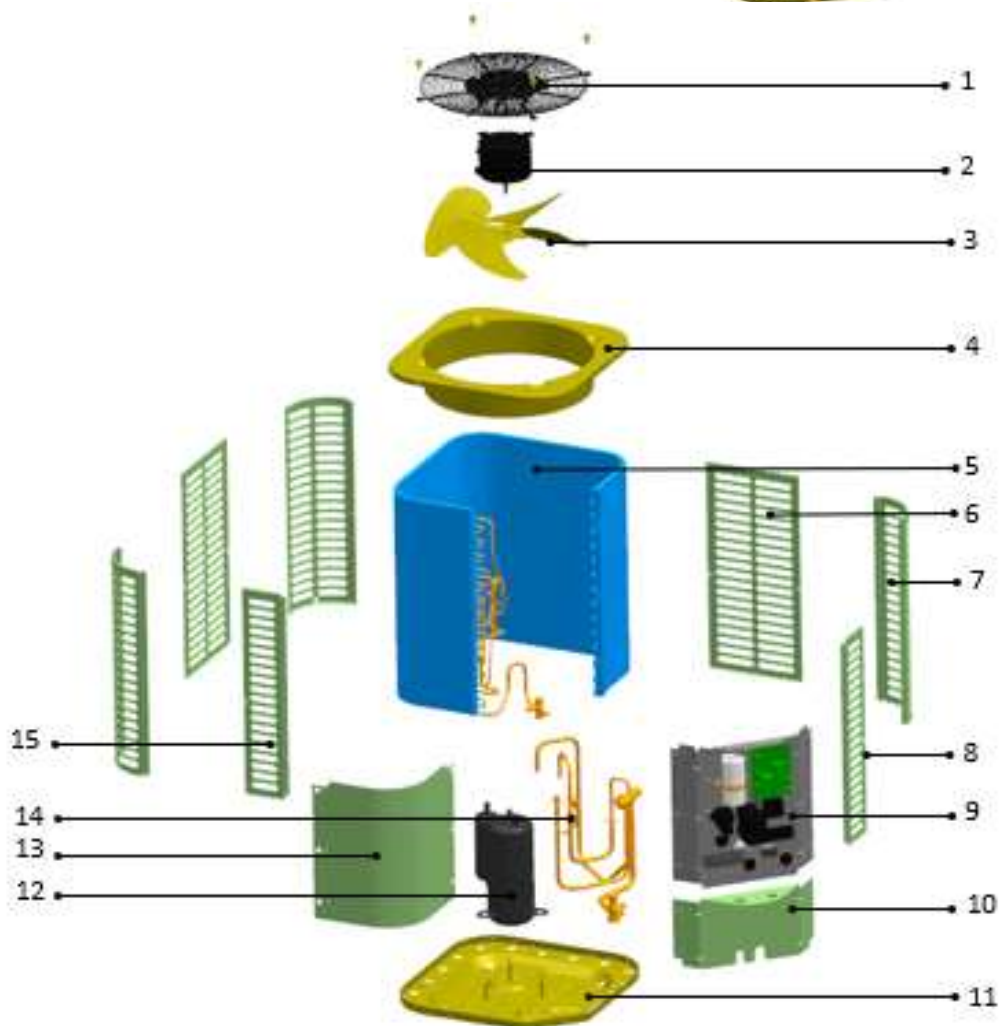

Exploded View CAC6013H18

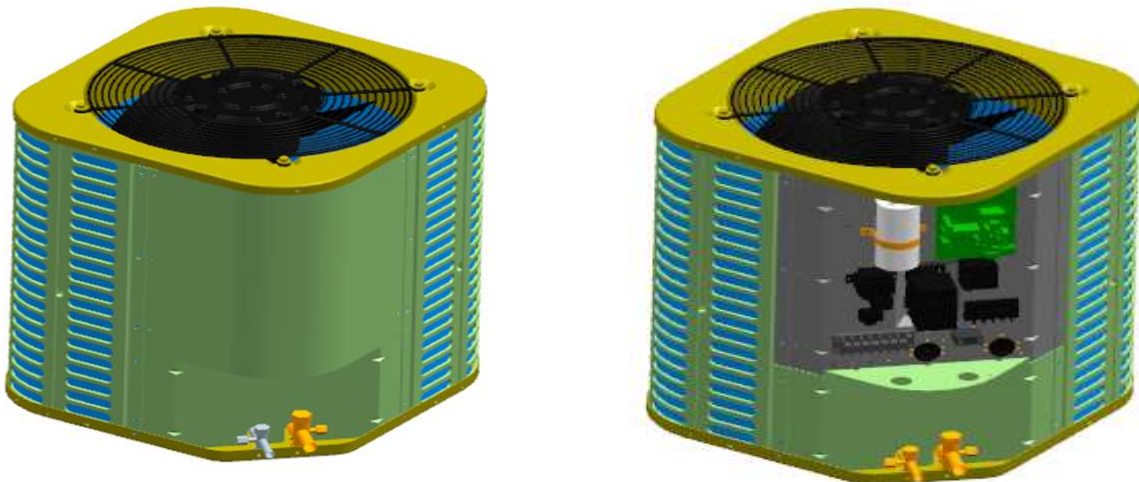
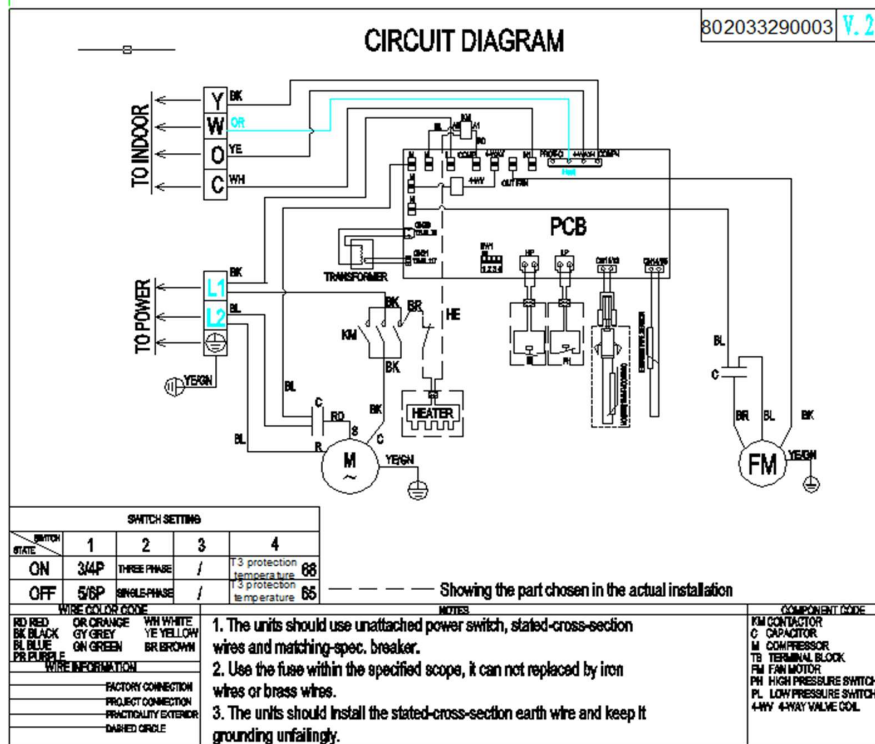

No.	Part No.	Part Name	Qty	Remark
1	802925490001	Cover net	1	
2	802400300077	Outdoor motor	1	
3	801200200055	Axial-flow fan	1	
4	801225490037	Top cover assembly	1	
5	801534490092	Condenser assembly	1	
5.1	801534090022	Condenser	1	
5.2	801634490195	Condenser input pipe assembly	1	
5.3	801634490196	Condenser output pipe assembly	1	
5.3.1	801639090321		1	
5.3.1.1	801600900069	Square valve	1	
6	801225490039	Rear side-panel	2	
7	801225490047	Support board	3	
8	801225490045	Right side panel	1	
9	803339090065	Electronic components	1	
9.1	801239090306	Electric install board weld assembly	1	
9.2	802401800129	Terminal board	1	
9.3	802301700430	Outdoor Unit PCB	1	
9.4	802300300055	Reactor	1	
9.5	803300700113	Communication board	1	
10	801239090252	Lower side panel	1	
11	801225490186	Chassis assembly	1	
12	801400900053	Compressor	1	
13	801239090255	Top panel	1	



Exploded View CAC6013H18

No.	Part No.	Part Name	Qty	Remark
14	801634490186	Four way valve welding assembly	1	
14.1	801600100030	Four way valve	1	
14.2	801600900101	Square valve	1	
14.3	802300900041	Pressure switch	1	
15	801225490051	Left side panel	1	