

## Exploded View - CAC4213H14

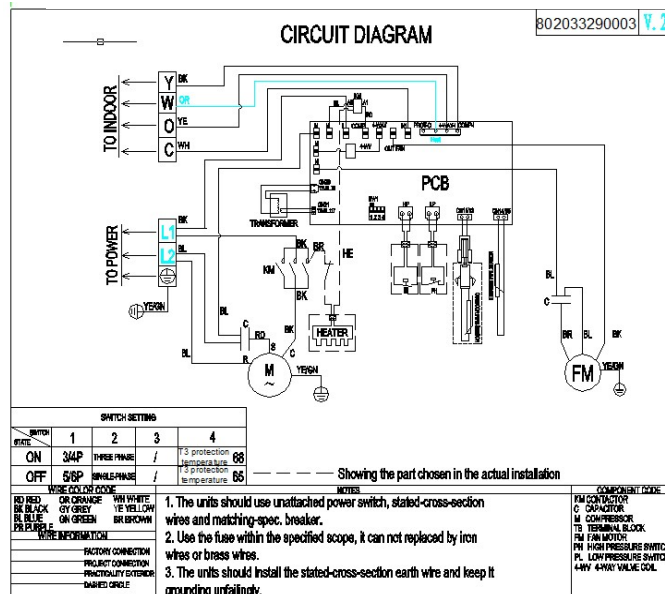

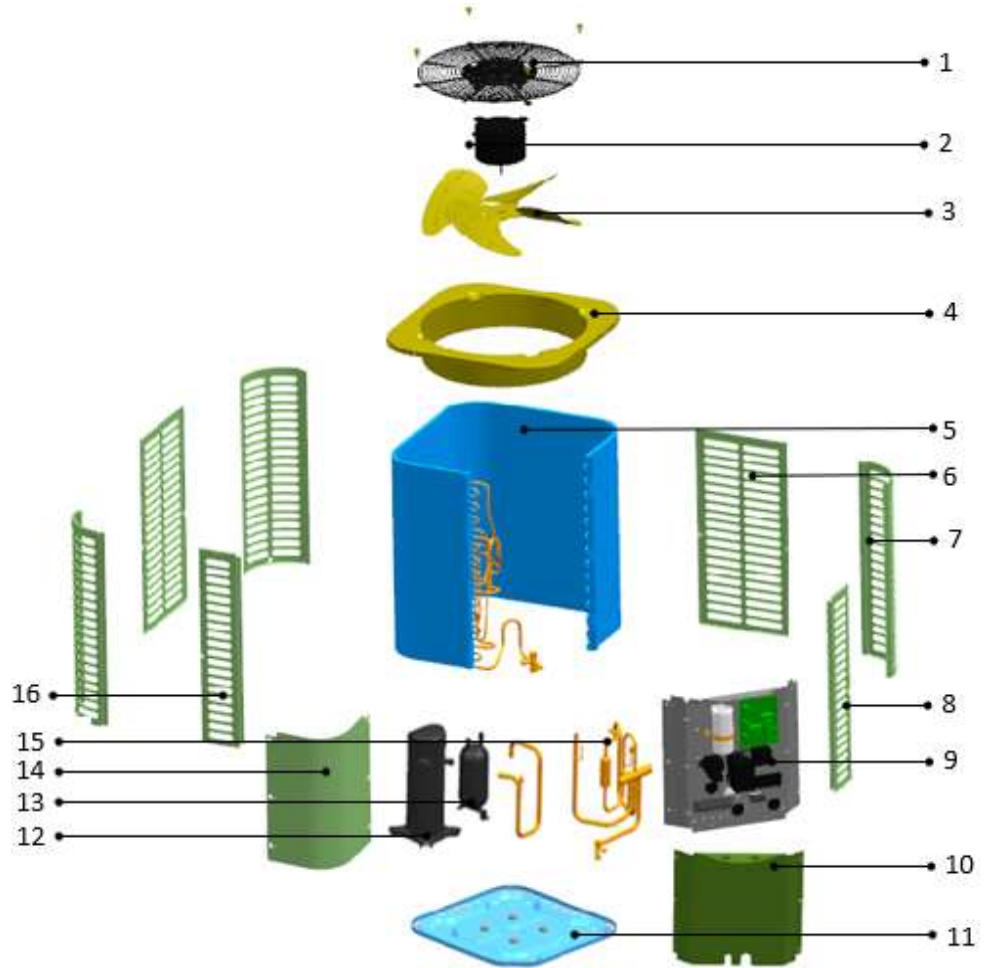

## Exploded View - CAC4213H14

No.	Part No.	Part Name	Qty	Remark
1	802925490001	Cover net	1	
2	802400400777	Outdoor motor	1	
3	802925490002	Axial-flow fan	1	
4	801225490037	Top cover assembly	1	
5	801533690004	Condenser assembly	1	
5.1	801533690003	Condenser	1	
5.2	801633690010	Condenser input pipe assembly	1	
5.3	801633690018	Condenser output pipe assembly	1	
5.3.1	801623690066	High-pressure valves weld assembly	1	
5.3.1.1	801600900069	Square valve	1	
6	801225490039	Rear side-panel	2	
7	801225490047	Support board	3	
8	801225490045	Right side panel	1	
9	803333690005	Electronic components	1	
9.1	801225490097	Electric install board weld assembly	1	
9.4	802300100261	AC Contactor	1	
9.5	802401000062	Fan capacitor	1	
9.6	802401000013	Compressor capacitor	1	
9.8	803300301099	Electronic control box	1	
10	801225490119	Left side panel	1	
11	801225490153	Chassis assembly	1	
12	801400100029	Compressor	1	
13	801625490049	Gas-liquid separator	1	
14	801225490041	Top panel	1	
15	801633690021	Four way valve welding assembly	1	
15.1	801600100030	Four way valve	1	
15.2	801600900072	Square valve	1	
15.3	802300900041	Pressure switch	1	
16	801225490051	Left side panel	1	