

Exploded View - CAC3013H14

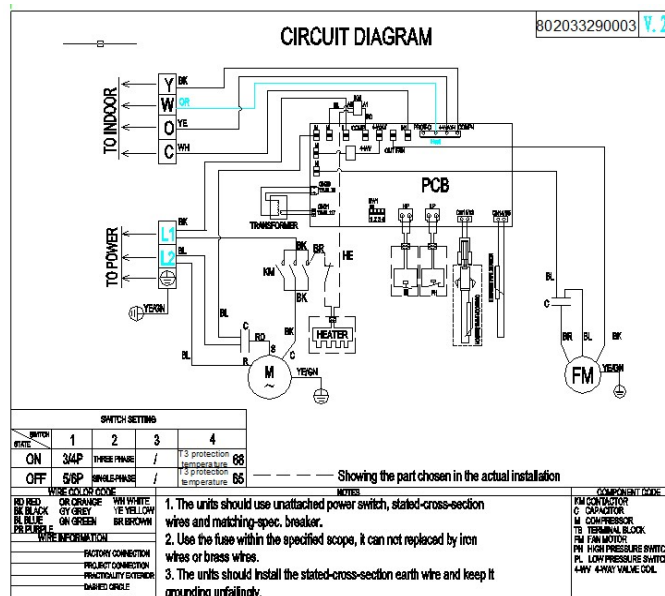

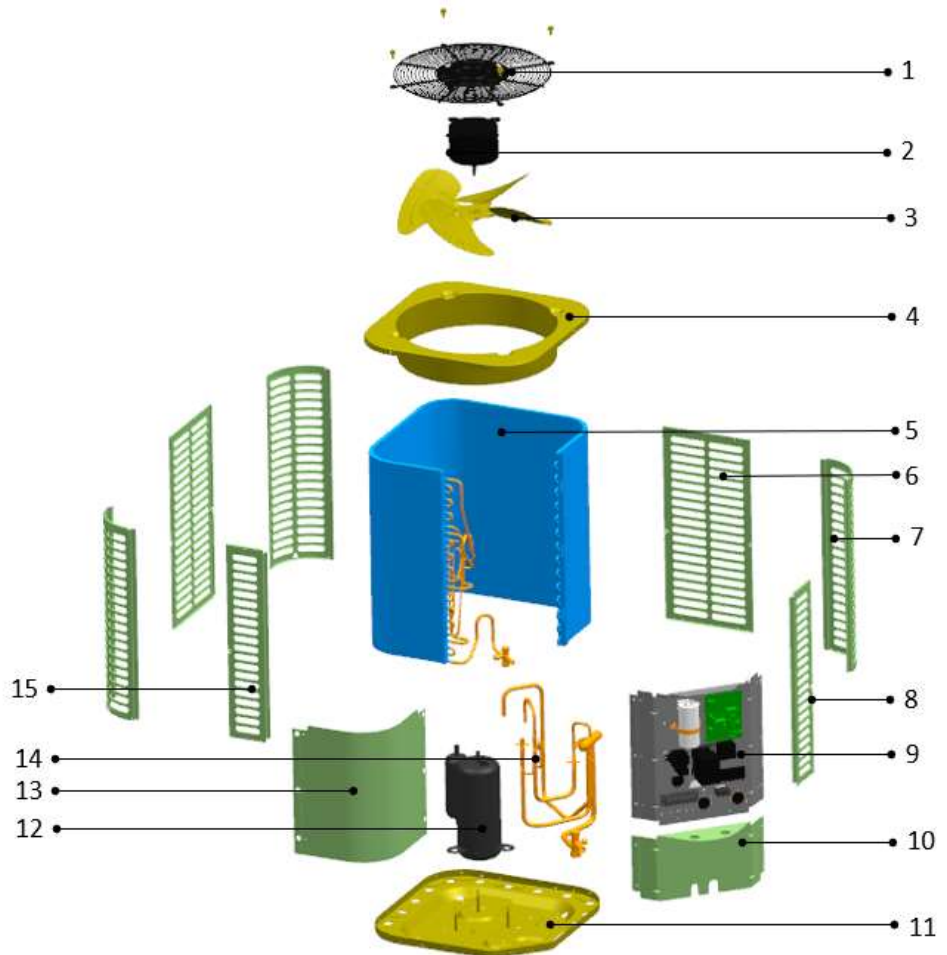

Exploded View - CAC3013H14

No.	Part No.	Part Name	Qty	Remark
1	802924290002	Cover net	1	
2	802400400778	Outdoor motor	1	
3	802919900009	Axial-flow fan	1	
4	801224290022	Top cover assembly	1	
5	801533490082	Condenser assembly	1	
5.1	801533490081	Condenser	1	
5.2	801624290237	Condenser input pipe assembly	1	
5.3	801624290244	Condenser output pipe assembly	1	
5.3.1	801625400002	Square valve	1	
6	801224290024	Rear side-panel	2	
7	801224290030	Support board	3	
8	801224290028	Right side panel	1	
9	803333290009	Electronic components	1	
9.1	801225490097	Electric install board weld assembly	1	
9.2	802300100261	AC Contactor	1	
9.3	802401000061	Fan motor capacitor	1	
9.4	802401000032	Compressor capacitor	1	
9.5	803300301099	Electronic control box	1	
10	801224290026	Left side panel	1	
11	801223290006	Chassis assembly	1	
12	801401100039	Compressor	1	
13	801225490041	Top panel	1	
14	801633290031	Four way valve welding assembly	1	
14.1	801600100027	Four way valve	1	
14.2	801600900072	Square valve	1	
14.3	802300900041	Pressure switch	1	
15	801224290034	Left side panel	1	