

## Exploded View - CAC1813H14

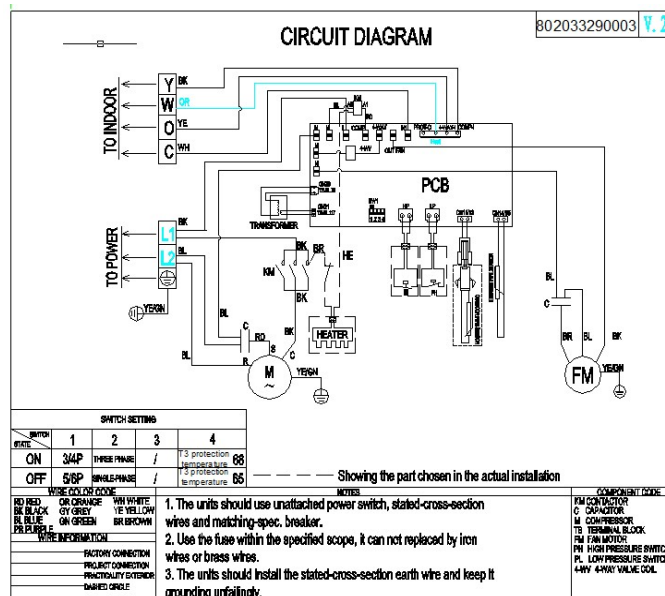

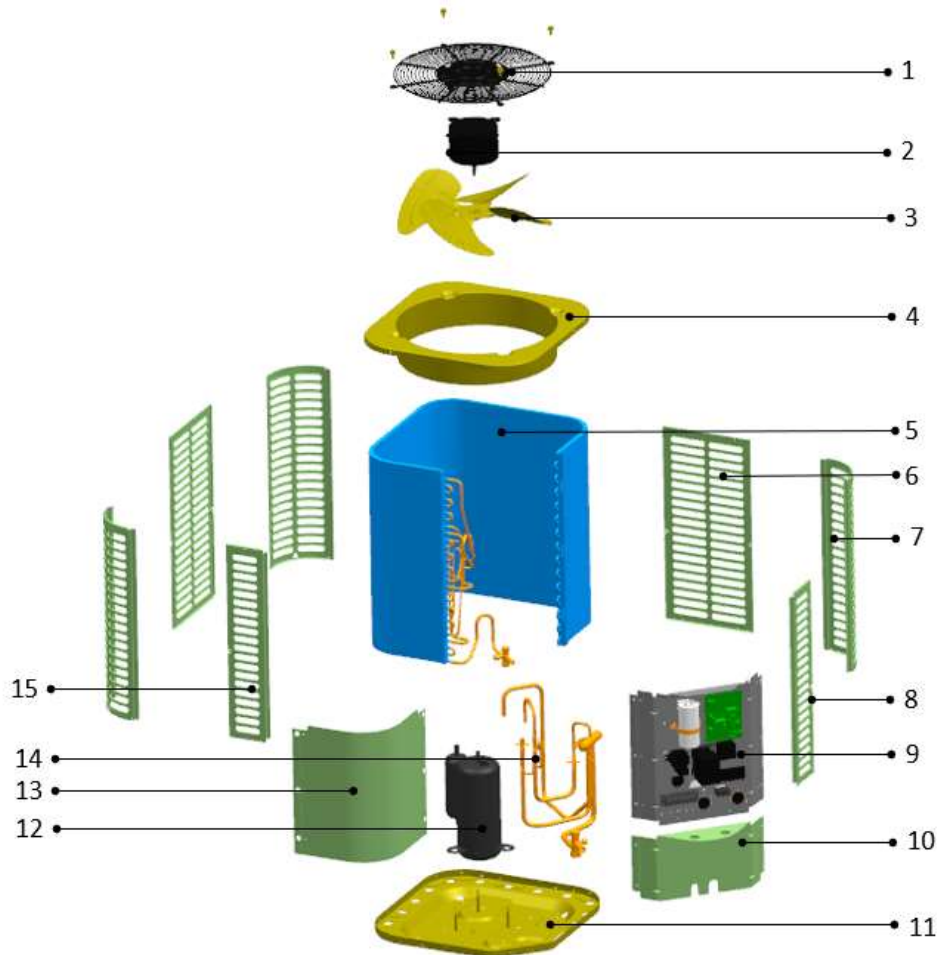

## Exploded View - CAC1813H14

No.	Part No.	Part Name	Qty	Remark
1	802924290002	Cover net	1	
2	802400400773	Outdoor motor	1	
3	802919900009	Axial-flow fan	1	
4	801224290022	Top cover assembly	1	
5	801532490042	Condenser assembly	1	
5.1	801532490040	Condenser	1	
5.2	801632490113	Condenser input pipe assembly	1	
5.3	801632490118	Condenser output pipe assembly	1	
5.3.1	801623690066	High-pressure valves weld assembly	1	
5.3.1.1	801600900069	Square valve	1	
6	801224290024	Rear side-panel	2	
7	801224290030	Support board	3	
8	801224290028	Right side panel	1	
9	803332490023	Electronic components	1	
9.1	801225490097	Electric install board weld assembly	1	
9.2	802300100261	AC Contactor	1	
9.3	802401000061	Fan motor capacitor	1	
9.4	802401000047	Compressor capacitor	1	
9.5	803300301099	Electronic control box	1	
10	801224290026	Left side panel	1	
11	801223290006	Chassis assembly	1	
12	801401100049	Compressor	1	
13	801225490041	Top panel	1	
14	801632490131	Four way valve welding assembly	1	
14.1	801600100027	Four way valve	1	
14.2	801600900072	Square valve	1	
14.3	802300900041	Pressure switch	1	
15	801224290034	Left side panel	1	