



SM_FOREST_60R410A_ONOFF_SA_NA_171117

FOREST ON-OFF SERIES

2017 SERVICE MANUAL

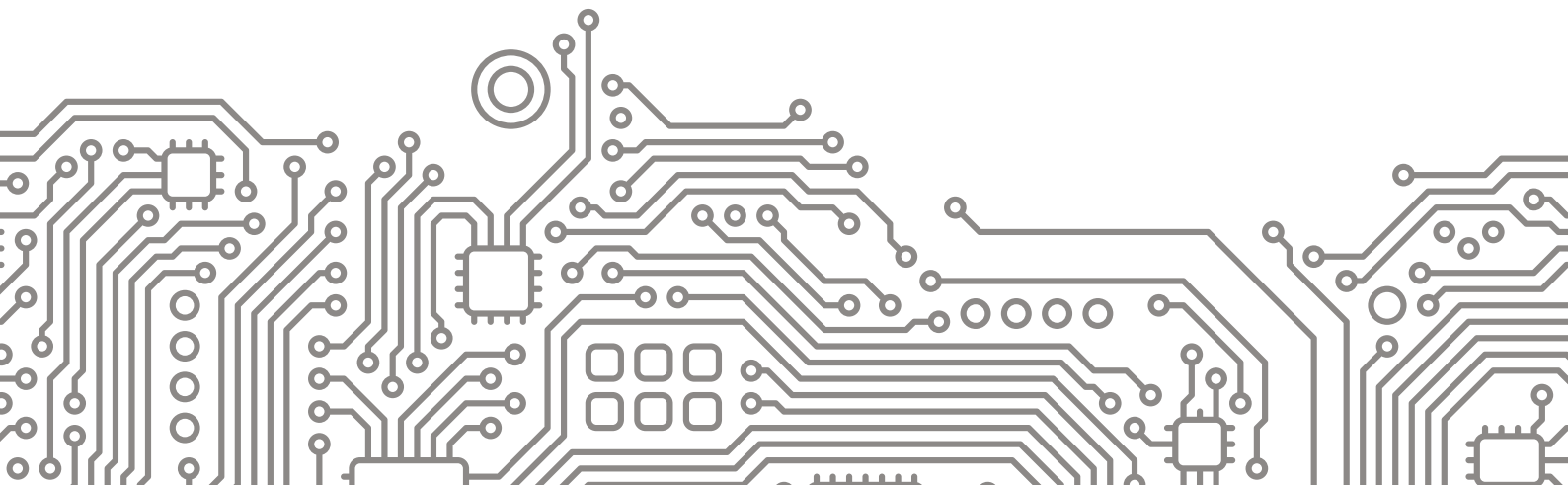
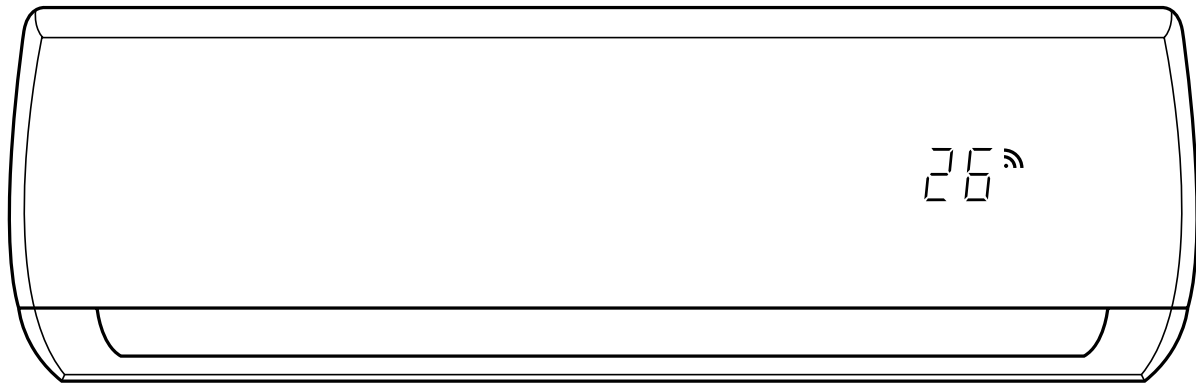

Table of Contents

Page

1. Safety Precautions	1
1. In case of Accidents or Emergency	
2. Pre-Installation and Installation	
3. Operation and Maintenance	
2. Specifications	3
1. Model Reference	
2. Electrical Wiring Diagrams	
3. Product Features	9
1. Operation Modes and Functions	
4. Maintenance and Disassembly	13
1. Maintenance	
2. Disassembly	
5. Troubleshooting	54
1. Safety Caution	
2. General Troubleshooting	
3. Error Diagnosis and Troubleshooting Without Error Code	
4. Quick Maintenance by Error Code	
5. Troubleshooting by Error Code	
Appendix	73
i) Temperature Sensor Resistance Value Table for T1,T2,T3 and T4 (°C – K)	
ii) Pressure On Service Port	

Safety Precautions

Contents

1.	In Case of Accidents or Emergency	2
2.	Pre-Installation.....	2
3.	Operation and Maintenance.....	2

To prevent personal injury, or property or unit damage, adhere to all precautionary measures and instructions outlined in this manual. Before servicing a unit, refer to this service manual and its relevant sections.

Failure to adhere to all precautionary measures listed in this section may result in personal injury, damage to the unit or to property, or in extreme cases, death.

! **WARNING** indicates a potentially hazardous situation which if not avoided could result in serious personal injury, or death.

! **CAUTION** indicates a potentially hazardous situation which if not avoided could result in minor or moderate personal injury, or unit damage.

1. In case of Accidents or Emergency

! WARNING

- If a gas leak is suspected, immediately turn off the gas and ventilate the area if a gas leak is suspected before turning the unit on.
- If strange sounds or smoke is detected from the unit, turn the breaker off and disconnect the power supply cable.
- If the unit comes into contact with liquid, contact an authorized service center.
- If liquid from the batteries makes contact with skin or clothing, immediately rinse or wash the area well with clean water.
- Do not insert hands or other objects into the air inlet or outlet while the unit is plugged in.
- Do not operate the unit with wet hands.
- Do not use a remote controller that has previously been exposed to battery damage or battery leakage.

! CAUTION

- Clean and ventilate the unit at regular intervals when operating it near a stove or near similar devices.
- Do not use the unit during severe weather conditions. If possible, remove the product from the window before such occurrences.

2. Pre-Installation and Installation

! WARNING

- Use this unit only on a dedicated circuit.
- Damage to the installation area could cause the unit to fall, potentially resulting in personal injury, property damage, or product failure.
- Only qualified personnel should disassemble, install, remove, or repair the unit.
- Only a qualified electrician should perform electrical work. For more information, contact your dealer, seller, or an authorized Midea service center.

! CAUTION

- While unpacking be careful of sharp edges around the unit as well as the edges of the fins on the condenser and evaporator.

3. Operation and Maintenance

! WARNING

- Do not use defective or under-rated circuit breakers.
- Ensure the unit is properly grounded and that a dedicated circuit and breaker are installed.
- Do not modify or extend the power cable. Ensure the power cable is secure and not damaged during operation.
- Do not unplug the power supply plug during operation.
- Do not store or use flammable materials near the unit.
- Do not open the inlet grill of the unit during operation.
- Do not touch the electrostatic filter if the unit is equipped with one.
- Do not block the inlet or outlet of air flow to the unit.
- Do not use harsh detergents, solvents, or similar items to clean the unit. Use a soft cloth for cleaning.
- Do not touch the metal parts of the unit when removing the air filter as they are very sharp.
- Do not step on or place anything on the unit or outdoor units.
- Do not drink water drained from the unit
- Avoid direct skin contact with water drained from the unit.
- Use a firm stool or step ladder according to manufacturer procedures when cleaning or maintaining the unit.

! CAUTION

- Do not install or operate the unit for an extended period of time in areas of high humidity or in an environment directly exposing it to sea wind or salt spray.
- Do not install the unit on a defective or damaged installation stand, or in an unsecure location.
- Ensure the unit is installed at a level position
- Do not install the unit where noise or air discharge created by the outdoor unit will negatively impact the environment or nearby residences.
- Do not expose skin directly to the air discharged by the unit for prolonged periods of time.
- Ensure the unit operates in areas water or other liquids.
- Ensure the drain hose is installed correctly to ensure proper water drainage.
- When lifting or transporting the unit, it is recommended that two or more people are used for this task.
- When the unit is not to be used for an extended time, disconnect the power supply or turn off the breaker.

Specifications

Contents

1.	Model Reference.....	4
2.	Electrical Wiring Diagrams.....	5
2.1	Indoor Unit.....	5
2.2	Outdoor Unit.....	7

1. Model Reference

Refer to the following table to determine the specific indoor and outdoor unit model number of your purchased equipment.

Indoor Unit Model	Outdoor Unit Model	Capacity (Btu)	Power Supply
MSAFA-09CRN1-BB8	MOAA31-09CN1-BB8	9k	115V~, 60Hz, 1Phase
MSAFB-12CRN1-BB8	MOAB31-12CN1-BB8	12k	
MSAFB-12CRN1-BB8	MOAA31-12CN1-BB8		
MSAFA-09CRN1-NB6	MOAA30-09CN1-NB6	9k	220-230V~, 60Hz, 1Phase
MSAFA-09CRN1-NB8	MOAA31-09CN1-NB8		
MSAFB-12CRN1-NB8	MOAB32-12CN1-NB8	12k	
MSAFB-12CRN1-NB8	MOAA31-12CN1-NB8		
MSAFB-12CRN1-NB8	MOAB31-12CN1-NB8		
MSAFC-18CRN1-NB8	MOBA31-18CN1-NB8	18k	
MSAFC-18CRN1-NB8	MOBA32-18CN1-NB8		
MSAFD-24CRN1-NB8W	MOCA30-24CN1-NB8W	24k	

2. Electrical Wiring Diagrams

2.1 Indoor unit

Abbreviation	Paraphrase
Y/G	Yellow-Green Conductor
ION	Positive and Negative Ion Generator
CAP	Capacitor
PLASMA	Electronic Dust Collector
X Y E	To Central Controller or 485 wired Controller
L	LIVE
N	NEUTRAL
Heater	The Electric Heating Belt of Indoor Unit
T1	Indoor Room Temperature
T2	Coil Temperature of Indoor Heat Exchanger Middle

MSAFA-09CRN1-BB8; MSAFB-12CRN1-BB8; MSAFA-09CRN1-NB8; MSAFA-09CRN1-NB6; MSAFB-12CRN1-NB8; MSAFC-18CRN1-NB8

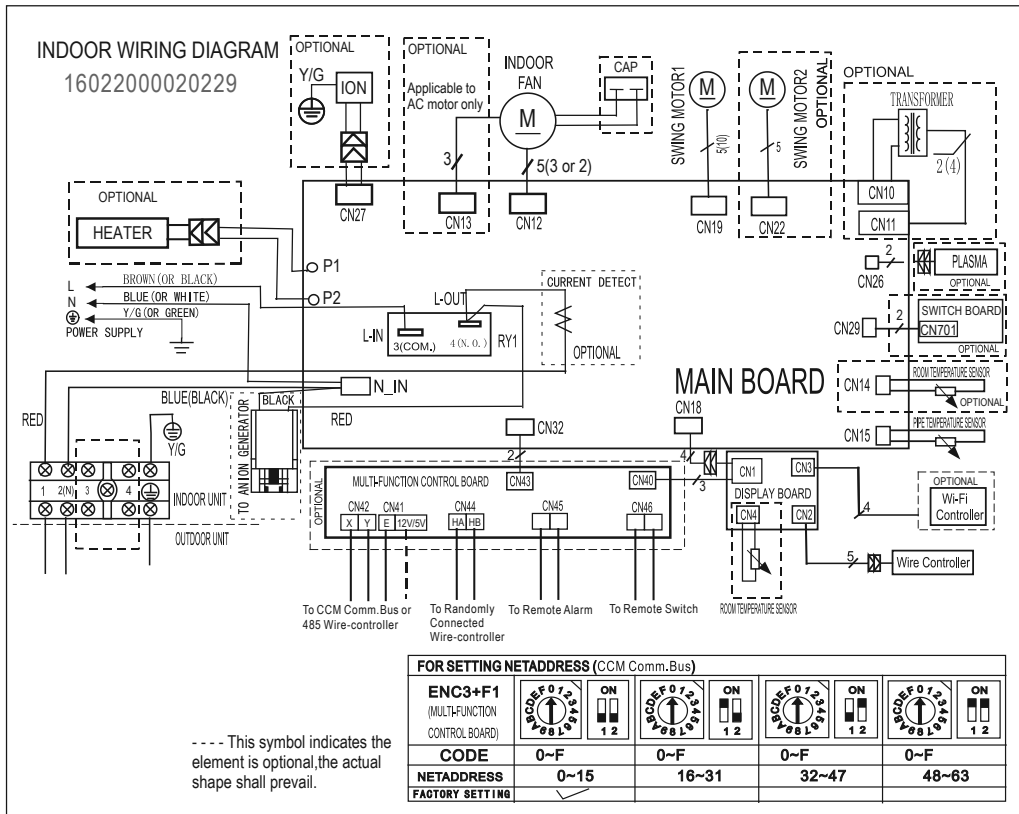

MSAFD-24CRN1-NB8W

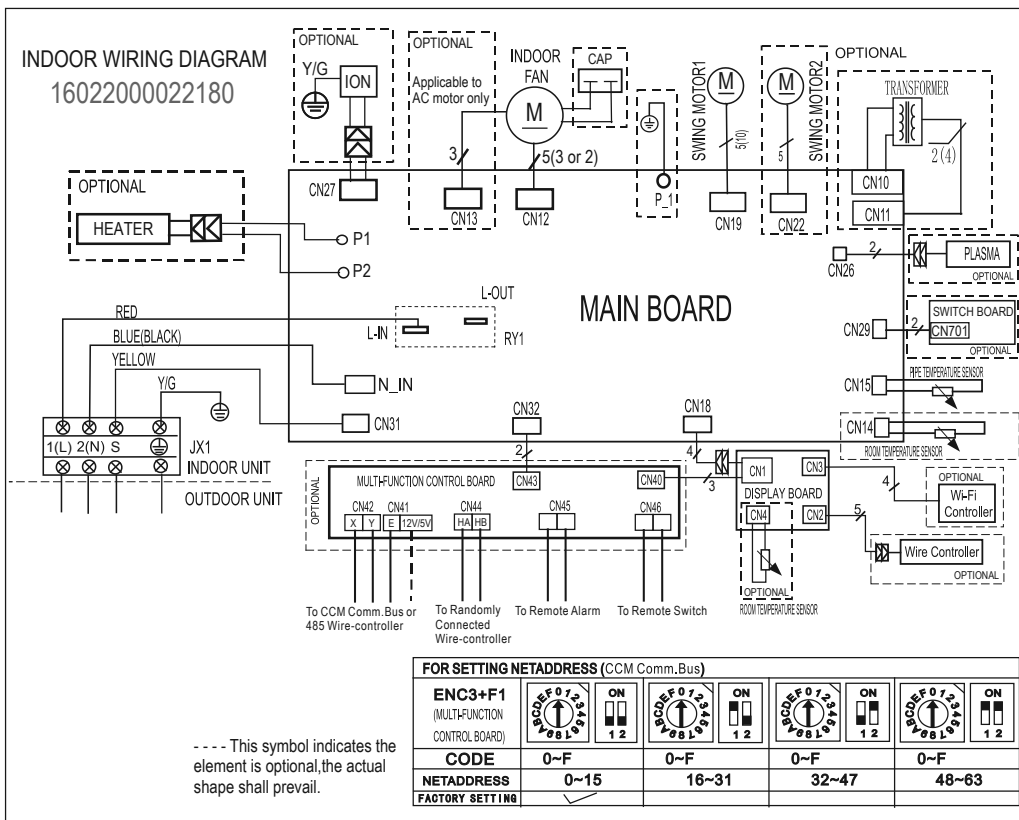

2.2 Outdoor Unit

Abbreviation	Paraphrase
4-WAY	Gas Valve Assembly/4-WAY VALVE
CT	AC Current Detector
COMP	Compressor
L-PRO	Low Pressure Switch
H-PRO	High Pressure Switch
T3, RT3	Coil Temperature of Condenser
T4	Outdoor Ambient Temperature
OLP	Overload Relay
CAP1	Compressor Capacitor
CAP2	Outdoor Fan Capacitor
UNIT1	Outdoor Control PCB
KM1	AC Contactor
TRANS	Transformer

MOAA31-09CN1-BB8, MOAB31-12CN1-BB8, MOAA31-12CN1-BB8, MOAA30-09CN1-NB6, MOAA31-09CN1-NB8, MOAB32-12CN1-NB8, MOAA31-12CN1-NB8, MOAB31-12CN1-NB8

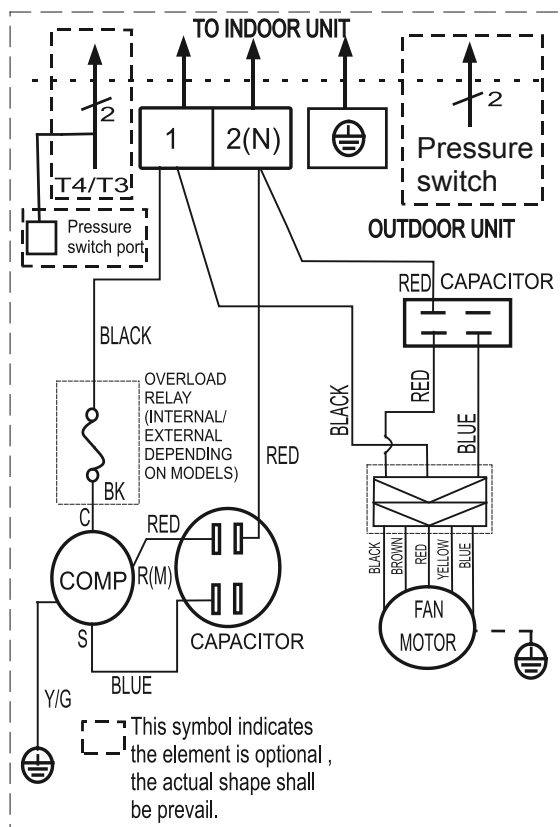

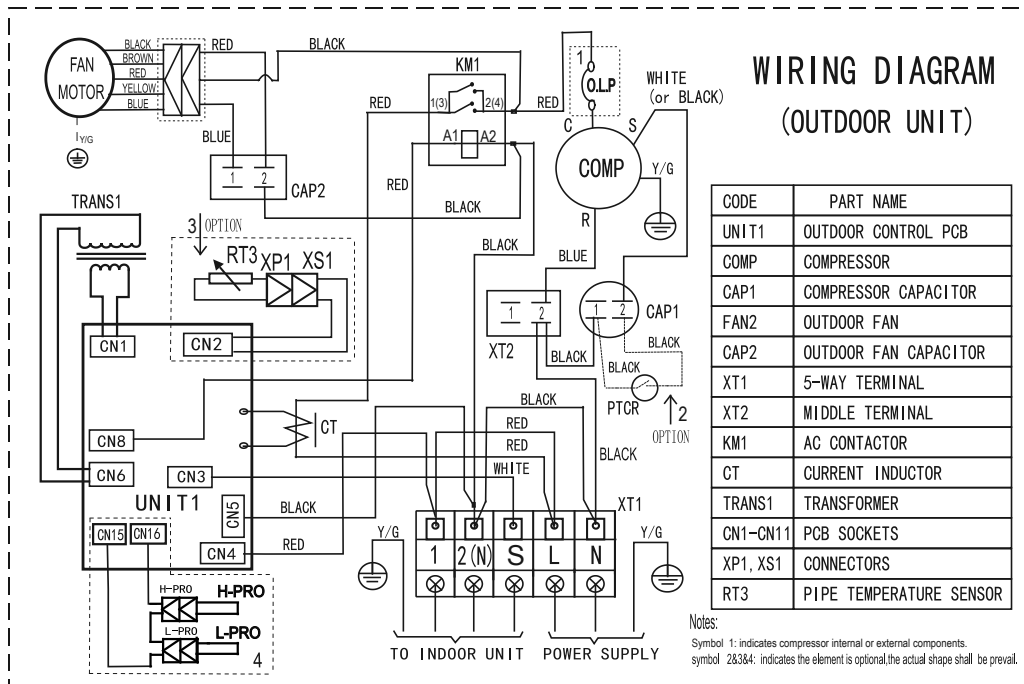
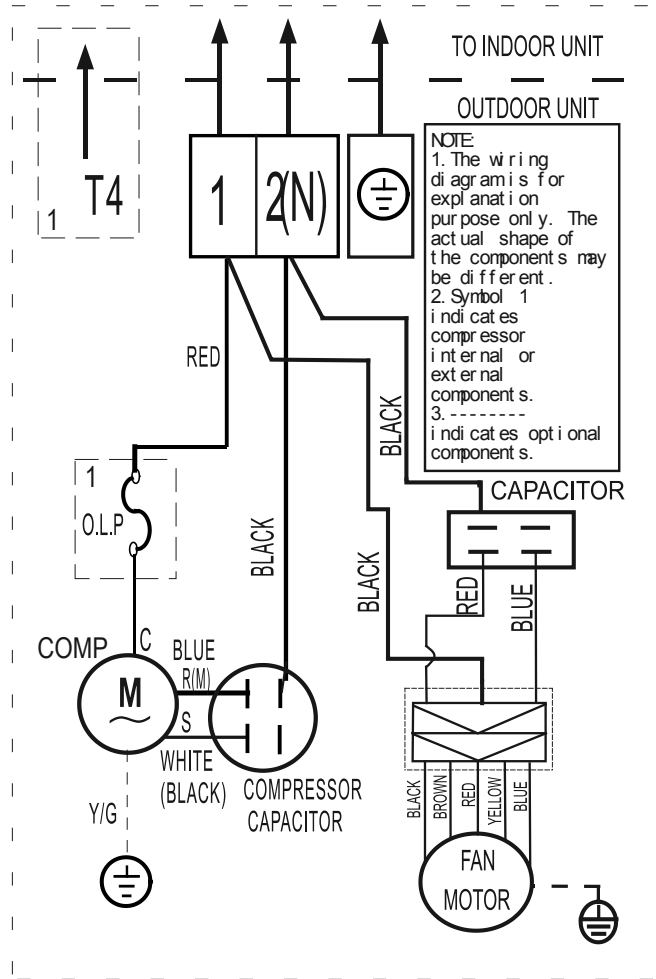

Product Features

Contents

1.	Operation Modes and Functions	10
1.1	Abbreviation.....	10
1.2	Safety Features	10
1.3	Digital Display.....	10
1.4	Fan Mode.....	11
1.5	Cooling Mode	11
1.6	Auto-mode.....	11
1.7	Drying Mode	11
1.8	Forced Operation Function	11
1.9	Auto-Restart Function.....	11
1.10	Refrigerant Leakage Detection	12
1.11	Self Clean(Optional).....	12
1.12	Follow Me(Optional).....	12
1.13	Information Inquiry.....	12

1. Operation Modes and Functions

1.1 Abbreviation

Unit element abbreviations

Abbreviation	Element
T1	Indoor room temperature
T2	Coil temperature of evaporator
T3	Coil temperature of condenser
T4	Outdoor ambient temperature

1.2 Safety Features

Compressor three-minute delay at restart

Compressor functions are delayed for up to one minute upon the first startup of the unit, and are delayed for up to three minutes upon subsequent unit restarts.

Zero crossing detection error protection

If AC can not detect zero crossing signal for 4 minutes or the zero crossing signal time interval is not correct, the unit will stop and the LED will display the failure. The correct zero crossing signal time interval should be between 6-13ms.

Automatic shutoff based on fan speed

If the indoor fan speed registers below 300RPM for 2 minutes, the unit ceases operation and the corresponding error code is displayed on the indoor unit.

Current protection

The current exceeds setting value for certain time, the compressor and outdoor fan will shut off.

Indoor fan delayed operation

- When the unit starts, the louver is automatically activated and the indoor fan will operate after a period of 4 seconds.
- If the unit is in heating mode, the indoor fan is regulated by the anti-cold wind function.

Sensor redundancy and automatic shutoff

If one temperature sensor malfunctions, the air conditioner ceases operation.

Refrigerant leakage detection

This function is active only when cooling mode is selected. It will detect if the compressor is being damaged by refrigerant leakage or by compressor overload. This is measured using the coil temperature of evaporator T2 when the compressor is in operation.

1.3 Digital Display

Unit display functions



Function	Display
Temperature	Set temperature value
Temperature (fan and Drying mode)	Room temperature
Activation of Timer ON, Fresh, Swing, Turbo, or Silent	00 (3s)
Cancellation of Timer OFF, Fresh, Swing, Turbo, or Silent	0F (3s)
Defrost	dF
Warming in heating mode	cF
Self-clean (available on select units only)	SC
Heating in room temperature under 8°C	FP

1.4 Fan Mode

When fan mode is activated:

- The outdoor fan and compressor are stopped.
- Temperature control is disabled and no temperature setting is displayed.
- The indoor fan speed can be set to high, medium, low, or auto.
- The louver operations are identical to those in cooling mode.
- Auto fan: In fan-only mode, AC operates the same as auto fan in cooling mode with the temperature set at 24°C.

1.5 Cooling Mode

1.5.1 Compressor Control

When indoor room temp. T1 is lower than setting value, the compressor and outdoor fan will shut off.

1.5.2 Indoor Fan Control

In cooling mode, the indoor fan operates continuously. The fan speed can be set to high, medium, low, or auto.

1.5.3 Outdoor Fan Control

The On-off outdoor units have single fan speed. The outdoor fan will run following the compressor except when AC is in evaporator high temperature protection in heating mode, condenser high temperature protection in cooling mode, defrosting mode and the current protection.

1.5.4 Evaporator Temperature Protection

When evaporator temperature drops below a configured value, the compressor and outdoor fan ceases operations.

1.6 Auto-mode

- This mode can be selected with the remote controller.
- In auto mode, the machine selects cooling, heating, or fan-only mode on the basis of ΔT ($\Delta T = T1 - T_s$).

ΔT	Running mode
$\Delta T > 2\text{ }^\circ\text{C}$	Cooling
$-3\text{ }^\circ\text{C} \leq \Delta T \leq 2\text{ }^\circ\text{C}$	Fan-only
$\Delta T < -3\text{ }^\circ\text{C}$	Heating*

Heating*: In auto mode, cooling only models run the fan

- AC will run in auto mode in the below cases:
 - Pressing the forced auto button.
 - If AC is off, it will run in auto mode when the timer on function is active.

- After setting the mode, AC will run in auto mode if the compressor keeps not running for certain time.

1.7 Drying mode

- The compressor is cycled running with 10 minutes on and then 5 minutes off. The indoor fan will keep running at low speed.
- In drying mode, if room temperature is lower than 10°C, the compressor will stop and not resume until room temperature exceeds 13°C.
- The evaporator anti-freezing protection is the same as that in cooling mode.

1.8 Forced operation function

- Forced cooling mode:

The compressor and outdoor fan continue to run and the indoor fan runs at low speed. After running for 30 minutes, the AC will switch to auto mode with a preset temperature of 24°C.

- Forced auto mode:

Forced auto mode operates the same as normal auto mode with a preset temperature of 24°C.

- The unit exits forced operation when it receives the following signals:
 - Switch on
 - Switch off
 - Timer on
 - Timer off
 - Changes in:
 - mode
 - fan speed
 - sleeping mode

1.9 Auto-Restart function

- The indoor unit has an auto-restart module that allows the unit to restart automatically. The module automatically stores the current settings (not including the swing setting) and, in the case of a sudden power failure, will restore those setting automatically within 3 minutes after power returns.
- If the unit was in forced cooling mode, it will run in this mode for 30 minutes and turn to auto mode with temperature set to 24°C.
- If there is a power failure while the unit is running, the compressor starts 3 minutes after the unit restarts. If the unit was already off before the power failure, the compressor starts 20 seconds after the unit restarts.

1.10 Refrigerant Leakage Detection

- With this new technology, the display area will show “EC” when the outdoor unit detects refrigerant leakage.
- When compressor is active, the value of the Coil temperature of evaporator T2 has no change or very little change.

1.11 Self clean(Optional)

- If you press “Self Clean” when the unit is in cooling or drying mode:
 - For cooling models, the indoor unit will run in low fan mode for a certain time, then ceases operation.
 - For heat pump models, the indoor unit will run in fan-only mode, then low heat, and finally in fan-only mode.
- Self Clean keeps the indoor unit dry and prevents mold growth.

1.12 Follow me(Optional)

- If you press “Follow Me” on the remote, the indoor unit will beep. This indicates the follow me function is active.
- Once active, the remote control will send a signal

every 3 minutes, with no beeps. The unit automatically sets the temperature according to the measurements from the remote control.

- The unit will only change modes if the information from the remote control makes it necessary, not from the unit’s temperature setting.
- If the unit does not receive a signal for 7 minutes or you press “Follow Me,” the function turns off. The unit regulates temperature based on its own sensor and settings.

1.13 Information Inquiry

- To enter information inquiry status, complete the following procedure within ten seconds:
 - Press LED 3 times.
 - Press SWING 3 times.
- If you are successful, you will hear beeps for two seconds.
- Use the LED and SWING buttons to cycle through information displayed.
- Pressing LED will display the next code in the sequence. Pressing SWING will show the previous.
- The following table shows information codes. The screen will display this code for two seconds, then the information for 25 seconds.

Displayed code	Explanation	Displayed value	Meaning	Additional Notes
T1	Room temperature	-14—70	-14—70	1. All displayed temperatures use actual values. 2. All temperatures are displayed in °C regardless of remote used. 3. If the actual value exceeds the range, it will display the maximum value or minimum value.
T2	Indoor coil temperature			
T3	Outdoor coil temperature			

Maintenance and Disassembly

Contents

1. Maintenance	14
1.1 First Time Installation Check	14
1.2 Refrigerant Recharge	16
1.3 Re-Installation	17
1.3.1 Indoor Unit	17
1.3.2 Outdoor Unit	19
2. Disassembly	21
2.1 Indoor Unit.....	21
2.2 Outdoor Unit.....	33

1. Maintenance

1.1 First Time Installation Check

Air and moisture trapped in the refrigerant system affects the performance of the air conditioner by:

- Increasing pressure in the system.
- Increasing the operating current.
- Decreasing the cooling or heating efficiency.
- Congesting the capillary tubing due to ice build-up in the refrigerant circuit.
- Corroding the refrigerant system.

To prevent air and moisture from affecting the air conditioner's performance, the indoor unit, as well as the pipes between the indoor and outdoor unit, must be leak tested and evacuated.

Leak test (soap water method)

Use a soft brush to apply soapy water or a neutral liquid detergent onto the indoor unit connections and outdoor unit connections. If there is gas leakage, bubbles will form on the connection.

Air purging with vacuum pump

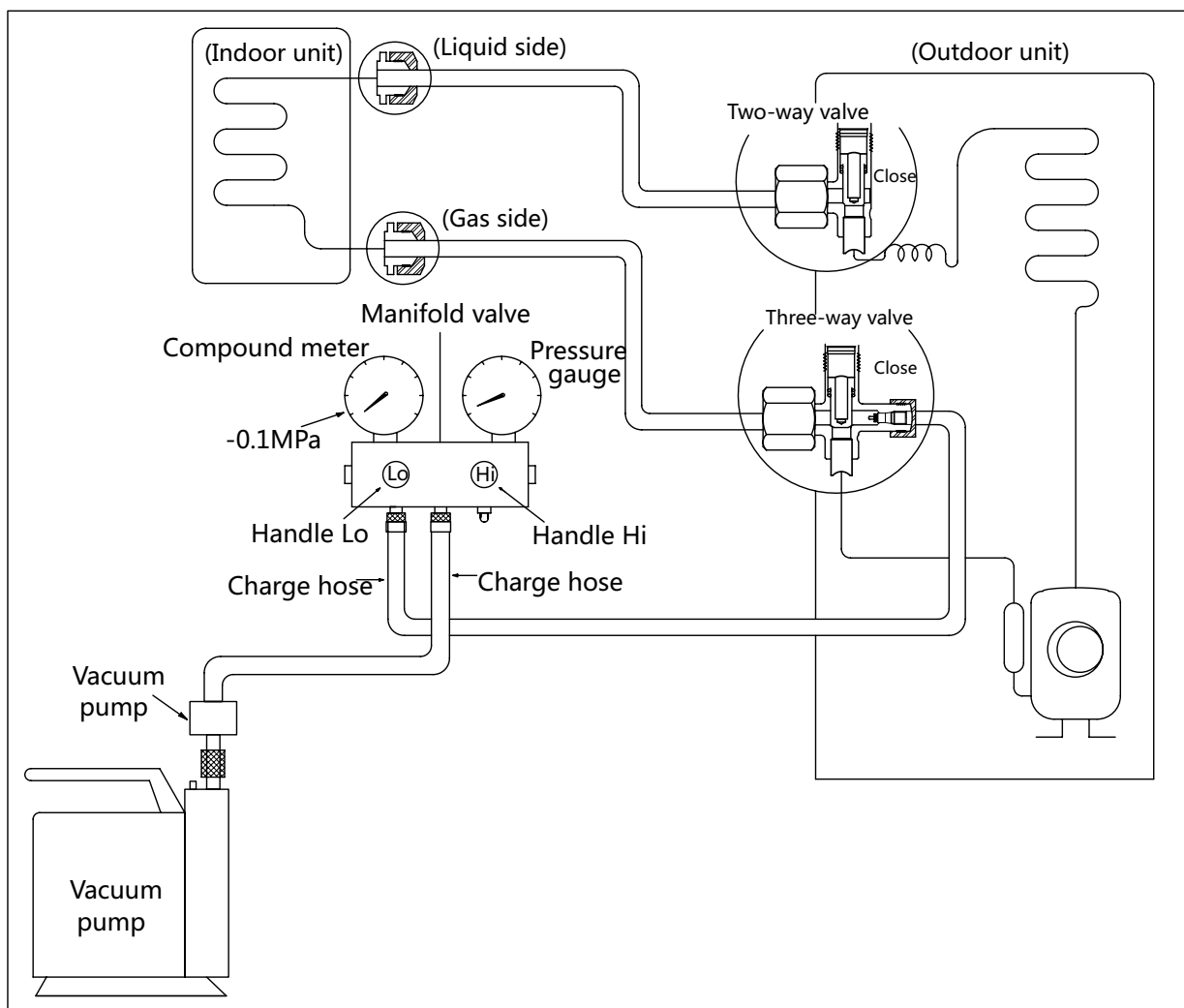

Procedure:

1. Tighten the flare nuts of the indoor and outdoor units, and confirm that both the 2- and 3-way valves are closed.
2. Connect the charge hose with the push pin of Handle Lo to the gas service port of the 3-way valve.
3. Connect another charge hose to the vacuum pump.
4. Fully open the Handle Lo manifold valve.
5. Using the vacuum pump, evacuate the system for 30 minutes.
 - a. Check whether the compound meter indicates -0.1 MPa (14.5 Psi).
 - If the meter does not indicate -0.1 MPa (14.5 Psi) after 30 minutes, continue evacuating for an additional 20 minutes.
 - If the pressure does not achieve -0.1 MPa (14.5 Psi) after 50 minutes, check for leakage.
 - b. If the pressure successfully reaches -0.1 MPa (14.5 Psi), fully close the Handle Lo valve, then cease vacuum pump operations.
6. Wait for 5 minutes then check whether the gauge needle moves after turning off the vacuum pump. If the gauge needle moves backward, check whether there is gas leakage.
6. Loosen the flare nut of the 3-way valve for 6 or 7 seconds and then tighten the flare nut again.
 - a. Confirm the pressure display in the pressure indicator is slightly higher than the atmospheric pressure.
 - b. Remove the charge hose from the 3-way valve.
7. Fully open the 2- and 3-way valves and tighten the cap of the 2- and 3-way valves.

1.2 Refrigerant Recharge

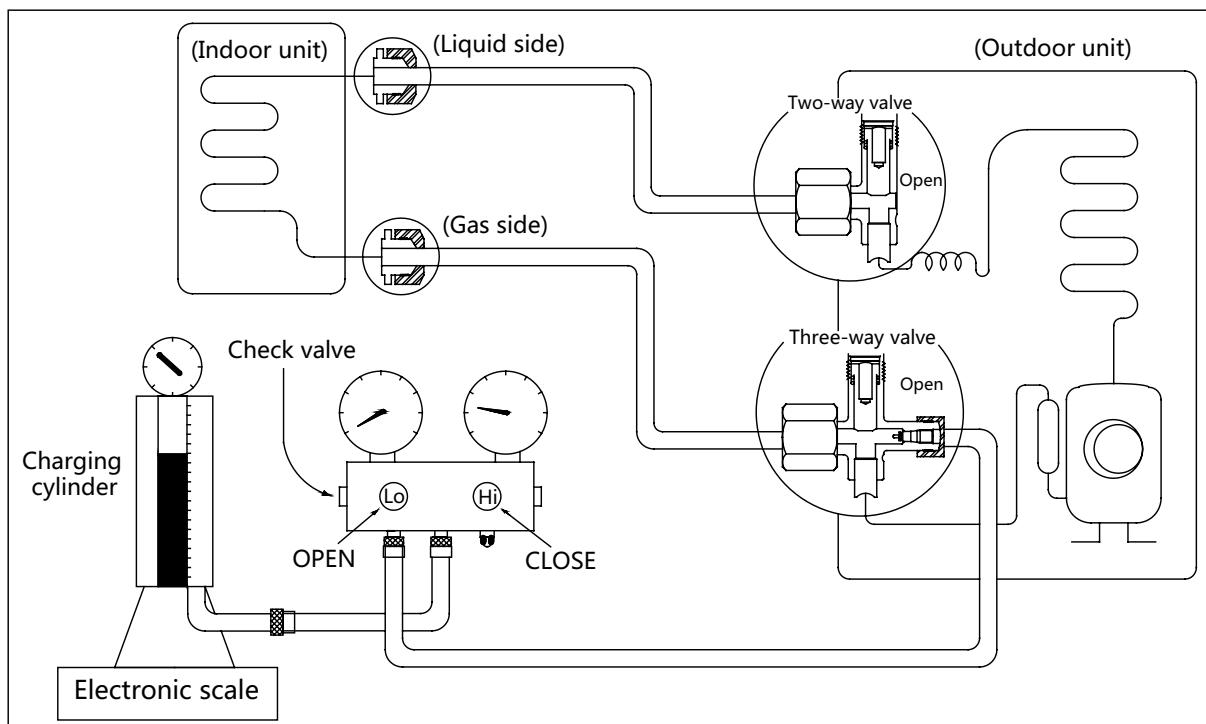

Prior to recharging the refrigerant, confirm the additional amount of refrigerant required using the following table:

Models	Standard length	Max. elevation	Max. length	Additional refrigerant
9k&12k	5m (16.4ft)	8m (26.2ft)	20m (65.6ft)	15g/m (0.16oz/ft)
18k	5m (16.4ft)	10m (32.8ft)	25m (82ft)	15g/m (0.16oz/ft)
24k	5m (16.4ft)	10m (32.8ft)	25m (82ft)	30g/m (0.32oz/ft)

Procedure:

1. Close both 2- and 3-way valves.
2. Slightly connect the Handle Lo charge hose to the 3-way service port.
3. Connect the charge hose to the valve at the bottom of the cylinder.
4. If the refrigerant is R410A, invert the cylinder to ensure a complete liquid charge.
5. Open the valve at the bottom of the cylinder for 5 seconds to purge the air in the charge hose, then fully tighten the charge hose with push pin Handle Lo to the service port of 3-way valve..
6. Place the charging cylinder onto an electronic scale and record the starting weight.
7. Fully open the Handle Lo manifold valve, 2- and 3-way valves.
8. Operate the air conditioner in cooling mode to charge the system with liquid refrigerant.
9. When the electronic scale displays the correct weight (refer to the gauge and the pressure of the low side to confirm), turn off the air conditioner, then disconnect the charge hose from the 3-way service port immediately..
10. Mount the caps of service port and 2- and 3-way valves.
11. Use a torque wrench to tighten the caps to a torque of 18 N.m.
12. Check for gas leakage.

1.3 Re-Installation

1.3.1 Indoor Unit

Collecting the refrigerant into the outdoor unit

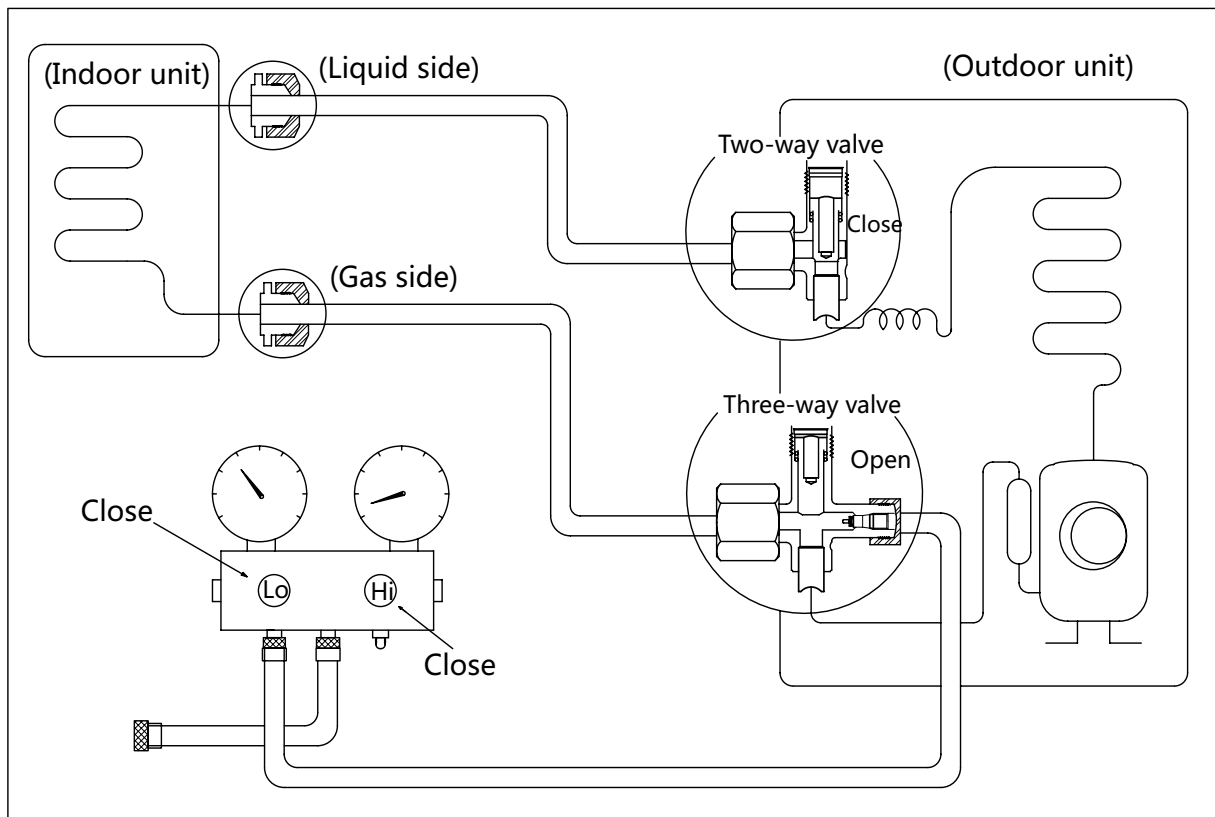

Procedure:

1. Confirm that the 2- and 3-way valves are opened.
2. Connect the charge hose with the push pin of Handle Lo to the 3-way valve's gas service port.
3. Open the Handle Lo manifold valve to purge air from the charge hose for 5 seconds and then close it quickly.
4. Close the 2-way valve.
5. Operate the air conditioner in cooling mode. Cease operations when the gauge reaches 0.1 MPa (14.5 Psi).
6. Close the 3-way valve so that the gauge rests between 0.3 MPa (43.5 Psi) and 0.5 MPa (72.5 Psi).
7. Disconnect the charge set and mount the caps of service port and 2- and 3-way valves.
8. Use a torque wrench to tighten the caps to a torque of 18 N.m.
9. Check for gas leakage.

Air purging with vacuum pump

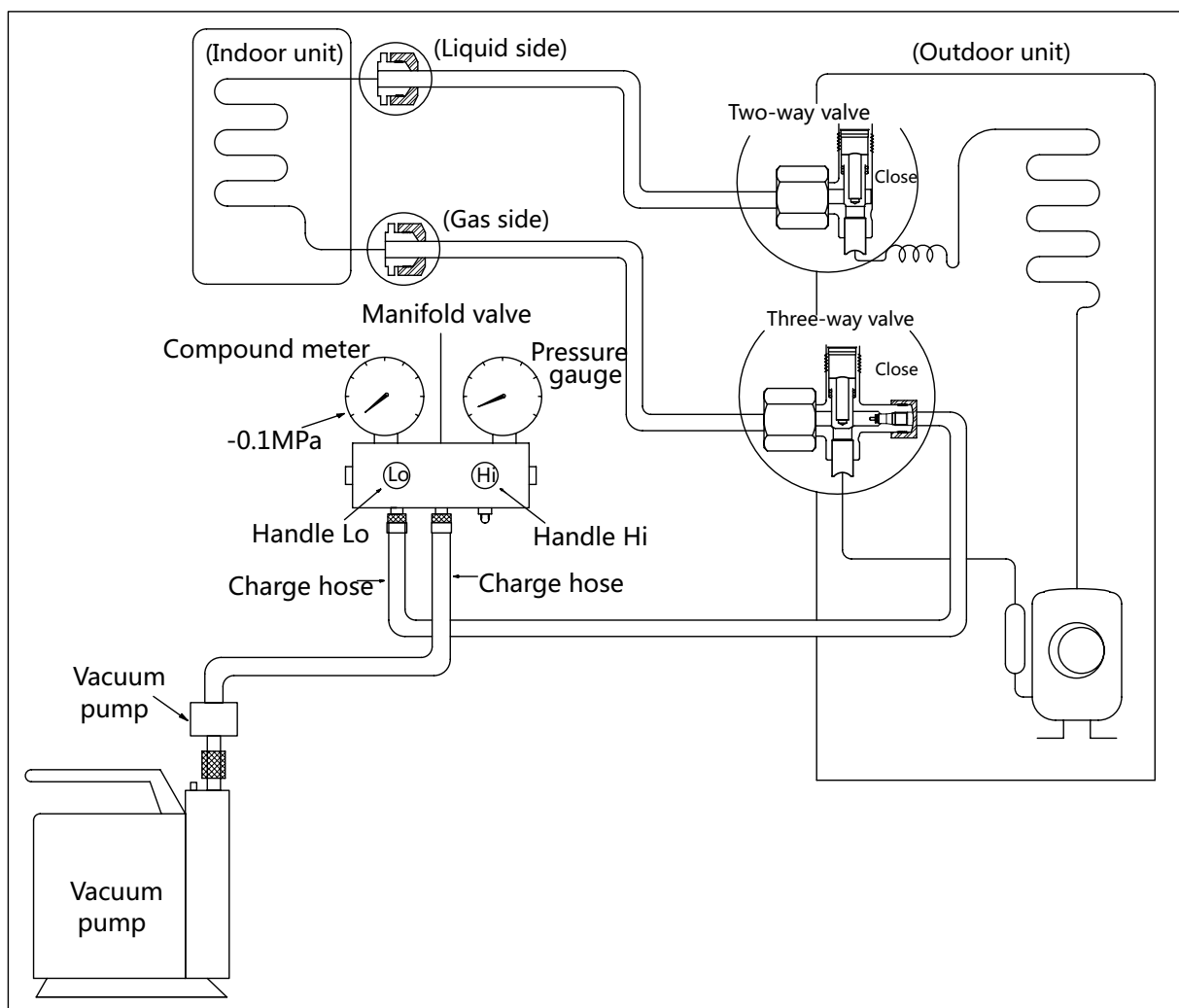

Procedure:

1. Tighten the flare nuts of the indoor and outdoor units, and confirm that both the 2- and 3-way valves are closed.
2. Connect the charge hose with the push pin of Handle Lo to the gas service port of the 3-way valve.
3. Connect another charge hose to the vacuum pump.
4. Fully open the Handle Lo manifold valve.
5. Using the vacuum pump, evacuate the system for 30 minutes.
 - a. Check whether the compound meter indicates -0.1 MPa (14.5 Psi).
 - If the meter does not indicate -0.1 MPa (14.5 Psi) after 30 minutes, continue evacuating for an additional 20 minutes.
 - If the pressure does not achieve -0.1 MPa (14.5 Psi) after 50 minutes, check for leakage.
 - If the pressure successfully reaches -0.1 MPa (14.5 Psi), fully close the Handle Lo valve, then cease vacuum pump operations.
 - b. Wait for 5 minutes then check whether the gauge needle moves after turning off the vacuum pump. If the gauge needle moves backward, check whether there is gas leakage.
6. Loosen the flare nut of the 3-way valve for 6 or 7 seconds and then tighten the flare nut again.
 - a. Confirm the pressure display in the pressure indicator is slightly higher than the atmospheric pressure.
 - b. Remove the charge hose from the 3-way valve.
7. Fully open the 2- and 3-way valves and tighten the cap of the 2- and 3-way valves.

1.3.2 Outdoor Unit

Evacuation for the whole system

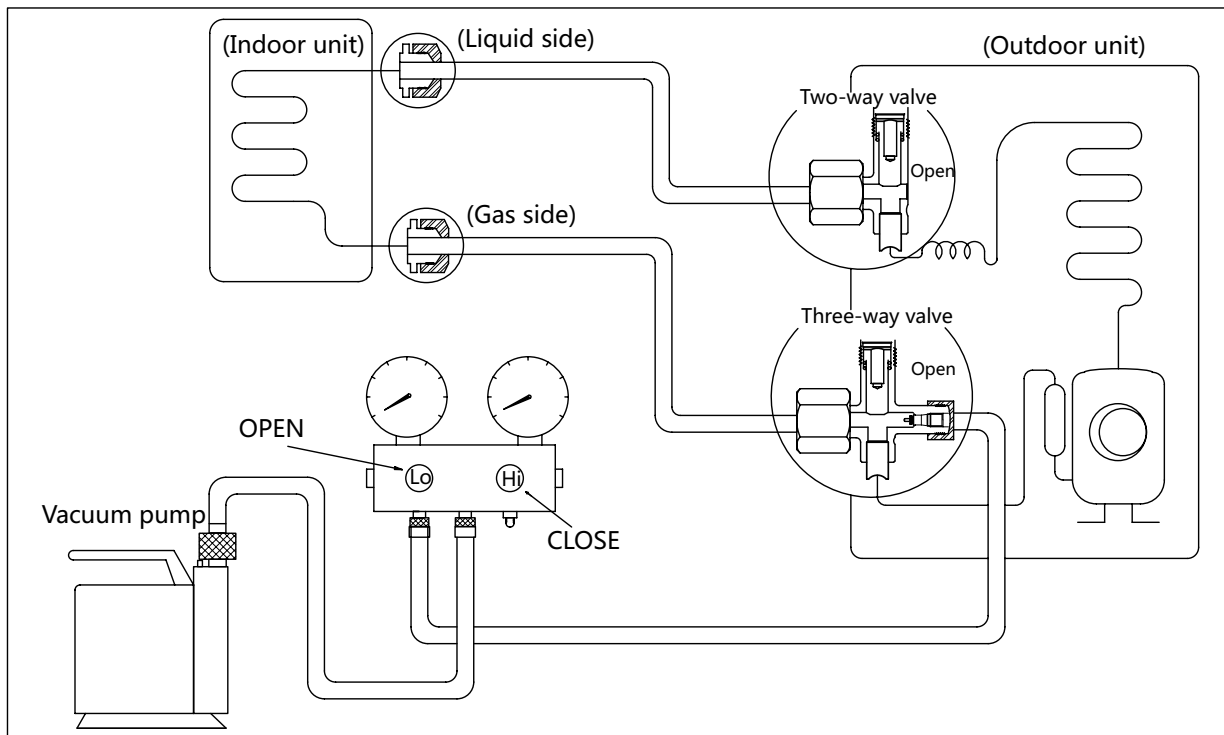

Procedure:

1. Confirm that the 2- and 3-way valves are opened.
2. Connect the vacuum pump to the 3-way valve's service port.
3. Evacuate the system for approximately one hour. Confirm that the compound meter indicates -0.1 MPa (14.5Psi).
4. Close the valve (Low side) on the charge set and turn off the vacuum pump.
5. Wait for 5 minutes then check whether the gauge needle moves after turning off the vacuum pump. If the gauge needle moves backward, check whether there is gas leakage.
6. Disconnect the charge hose from the vacuum pump.
7. Mount the caps of service port and 2- and 3-way valves.
8. Use a torque wrench to tighten the caps to a torque of 18 N.m.

Refrigerant charging

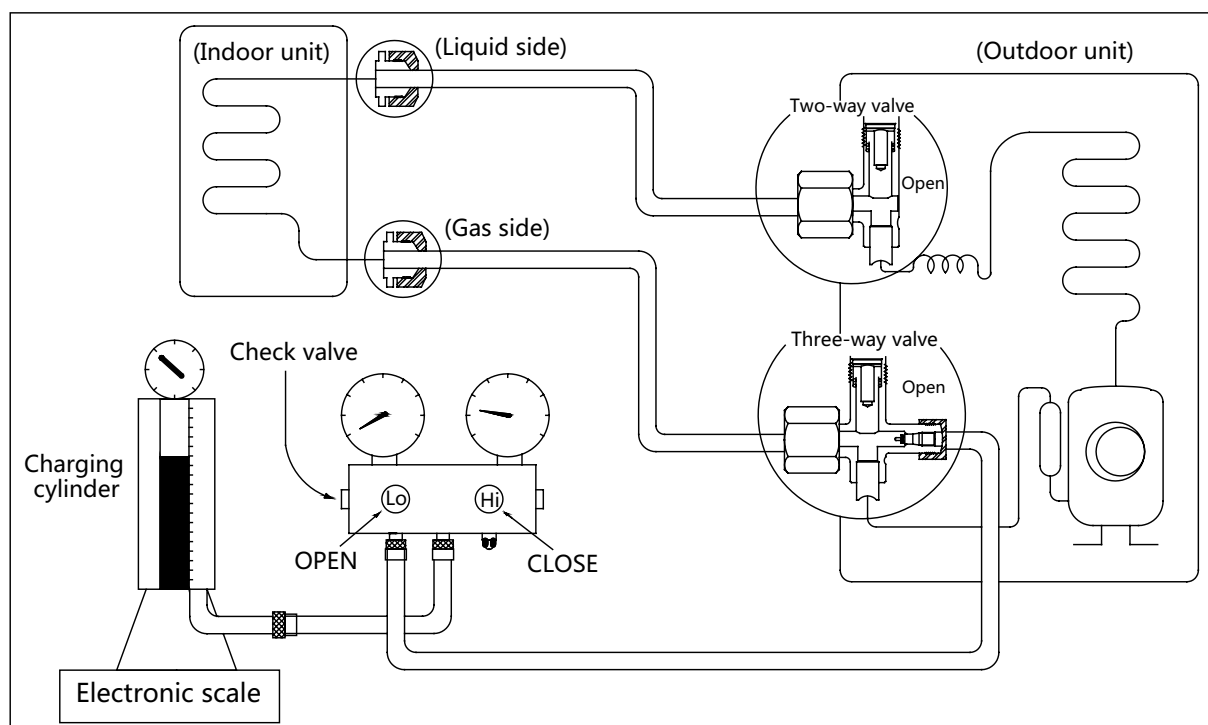

Procedure:

1. Close both 2- and 3-way valves.
2. Slightly connect the Handle Lo charge hose to the 3-way service port.
3. Connect the charge hose to the valve at the bottom of the cylinder.
4. If the refrigerant is R410A, invert the cylinder to ensure a complete liquid charge.
5. Open the valve at the bottom of the cylinder for 5 seconds to purge the air in the charge hose, then fully tighten the charge hose with push pin Handle Lo to the service port of 3-way valve..
6. Place the charging cylinder onto an electronic scale and record the starting weight.
7. Fully open the Handle Lo manifold valve, 2- and 3-way valves.
8. Operate the air conditioner in cooling mode to charge the system with liquid refrigerant.
9. When the electronic scale displays the correct weight (refer to the gauge and the pressure of the low side to confirm), turn off the air conditioner, then disconnect the charge hose from the 3-way service port immediately..
10. Mount the caps of service port and 2- and 3-way valves.
11. Use a torque wrench to tighten the caps to a torque of 18 N.m.
12. Check for gas leakage.

Note: 1. Mechanical connectors used indoors shall comply with local regulations.

2. When mechanical connectors are reused indoors, sealing parts shall be renewed. When flared joints are reused indoors, the flare part shall be re-fabricated.

2. Disassembly

2.1 Indoor unit

1. Front Panel

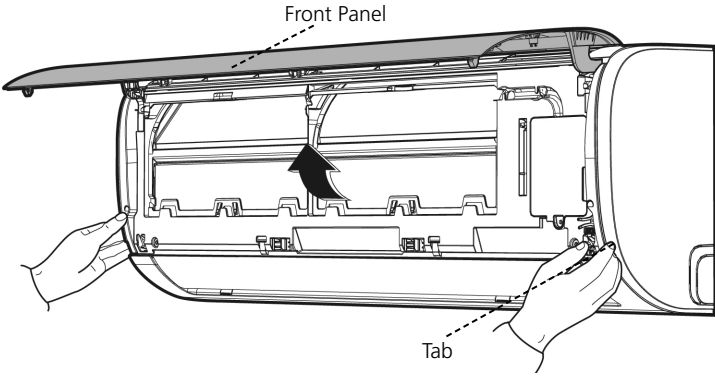
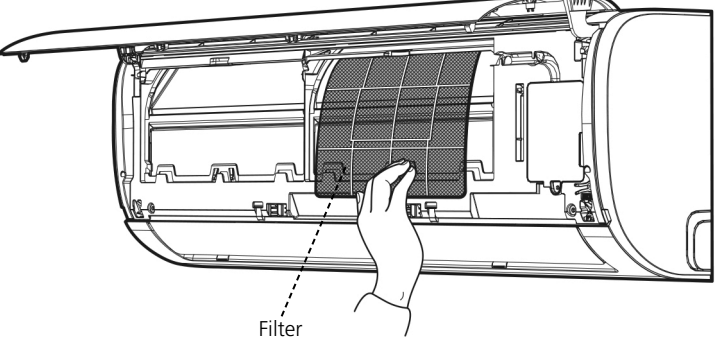
Procedure	Illustration
<p>1) Hold the front panel by the tabs on the both sides and lift it (see CJ_AF_001).</p>	 <p style="text-align: center;">CJ_AF_001</p>
<p>2) Push up the bottom of an air filter, and then pull it out downwards (see CJ_AF_002).</p>	 <p style="text-align: center;">CJ_AF_002</p>

Note: This section is for reference only. Actual unit appearance may vary.

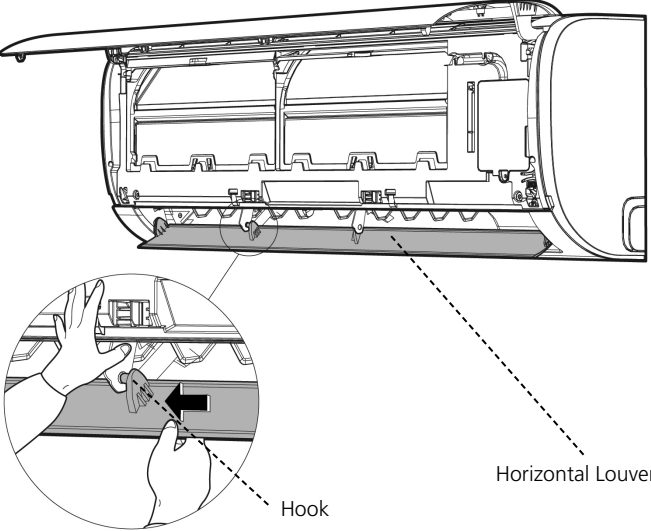
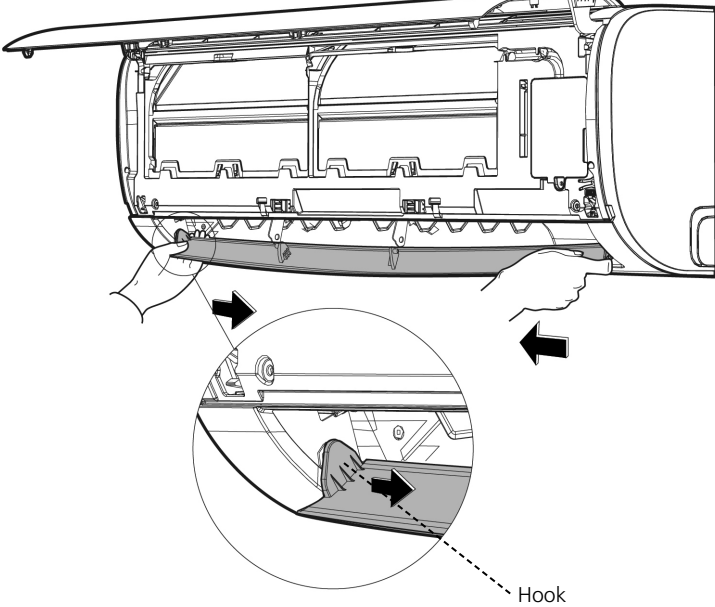
Procedure	Illustration
<p>3) Open the horizontal louver and push the hook towards left to open it (see CJ_AF_003).</p>	 <p>The diagram shows a side view of the horizontal louver assembly. A circular inset provides a magnified view of a hand pushing a hook to the left, as indicated by a black arrow. Labels 'Hook' and 'Horizontal Louver' are present. The code 'CJ_AF_003' is centered below the diagram.</p>
<p>4) Bend the horizontal louver lightly by both hands to loosen the hooks, then remove the horizontal louver (see CJ_AF_004).</p>	 <p>The diagram shows a side view of the horizontal louver assembly. A circular inset provides a magnified view of hands bending the louver, with arrows indicating the direction of force. A label 'Hook' points to the attachment point. The code 'CJ_AF_004' is centered below the diagram.</p>

Note: This section is for reference only. Actual unit appearance may vary.

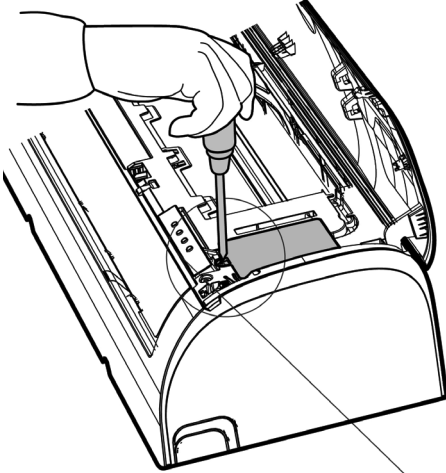
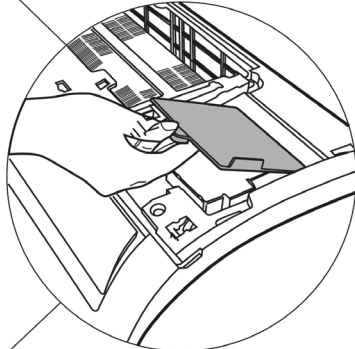
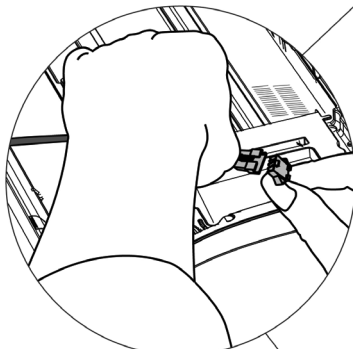
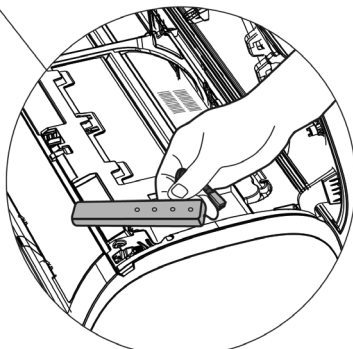
Procedure	Illustration
<p>5) Remove 1 screw and then remove the electrical cover(see CJ_AF_005-1 and CJ_AF_005-2).</p>	 <p>CJ_AF_005-1</p>  <p>CJ_AF_005-2</p>
<p>6) Disconnect the connector for display board(see CJ_AF_005-3) .</p>	 <p>CJ_AF_005-3</p>
<p>7) Remove the display board(see CJ_AF_005-4).</p>	 <p>CJ_AF_005-4</p> <p>CJ_AF_005</p>

Note: This section is for reference only. Actual unit appearance may vary.

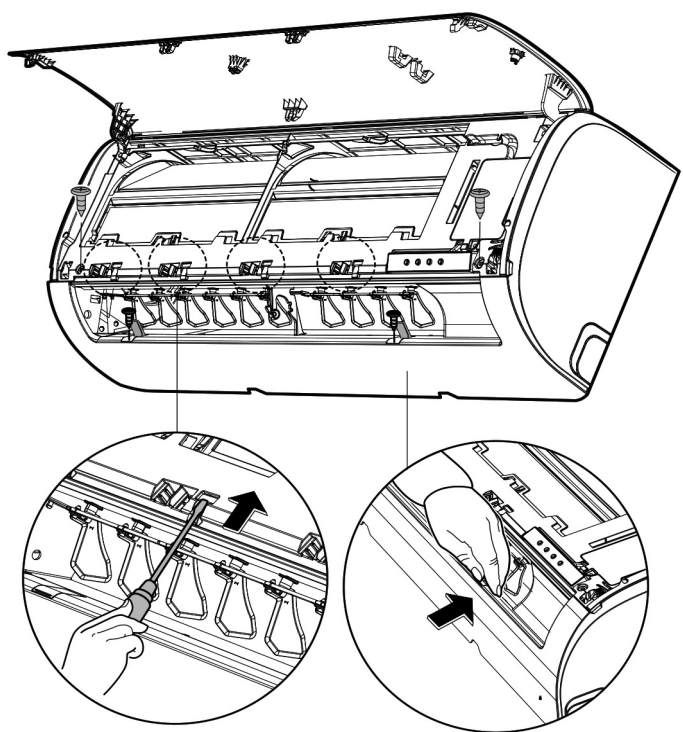
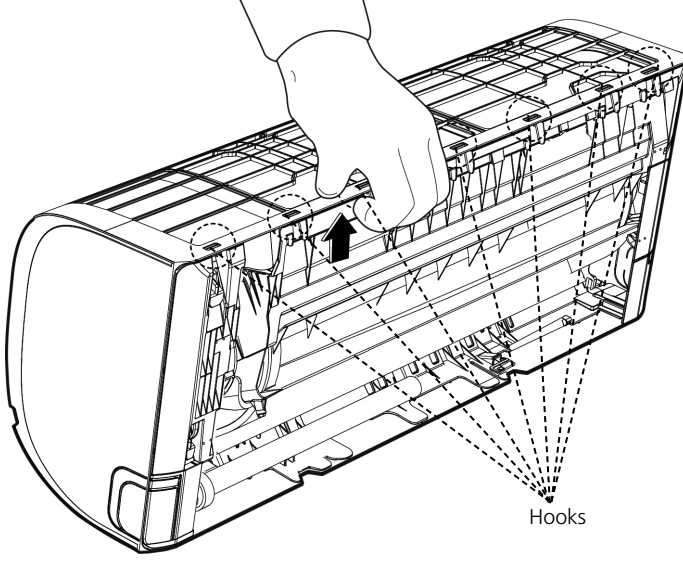
Procedure	Illustration
<p>8) Open the screw caps(2) and the remove the screws(see CJ_AF_006).</p> <p>9) Release the 4 hooks.</p>	 <p style="text-align: center;">CJ_AF_006</p>
<p>10)Release the seven hooks in the back (see CJ_AF_007).</p>	 <p style="text-align: center;">CJ_AF_007</p>

Note: This section is for reference only. Actual unit appearance may vary.

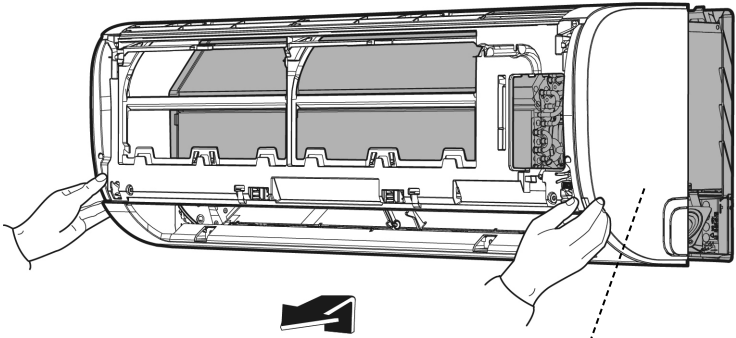
Procedure	Illustration
<p>11) Pull out the panel frame while pushing the hook through a clearance between the panel frame and the heat exchanger (see CJ_AF_008).</p>	 <p data-bbox="946 734 1086 763">CJ_AF_008</p> <p data-bbox="1171 734 1283 763">Panel Frame</p>

Note: This section is for reference only. Actual unit appearance may vary.

2. Electrical parts

Note: Remove the front panel (refer to 1. Front panel) before disassembling electrical parts.

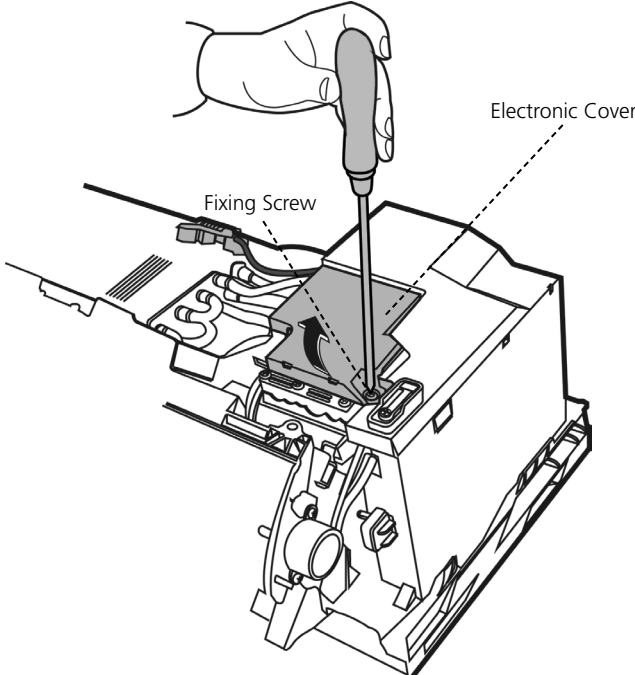
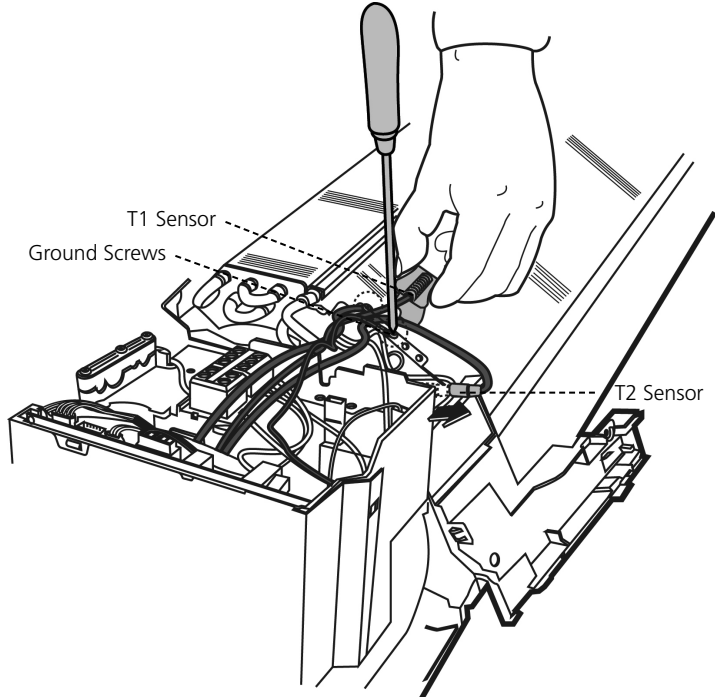
Procedure	Illustration
<p>1) Remove the fixing screw and then remove the cover of electronic box and the terminal cover (see CJ_AF_009).</p>	 <p style="text-align: center;">CJ_AF_009</p>
<p>2) Pull out the room temperature sensor (T1) and the coil temperature sensor (T2) (see CJ_AF_010).</p> <p>3) Remove the two screws used for the ground connection (see CJ_AF_010).</p>	 <p style="text-align: center;">CJ_AF_010</p>

Note: This section is for reference only. Actual unit appearance may vary.

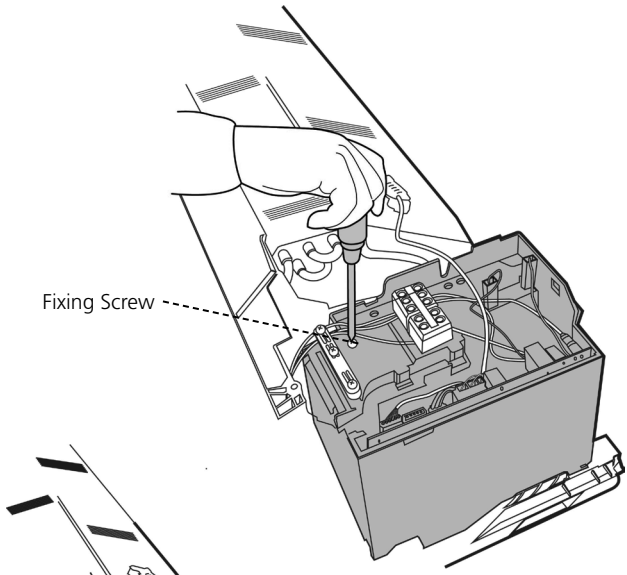
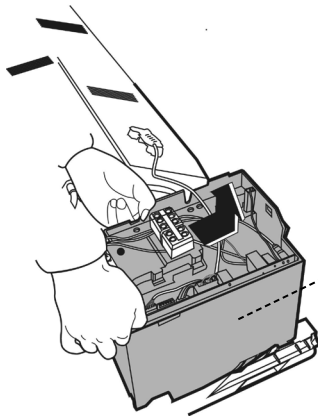
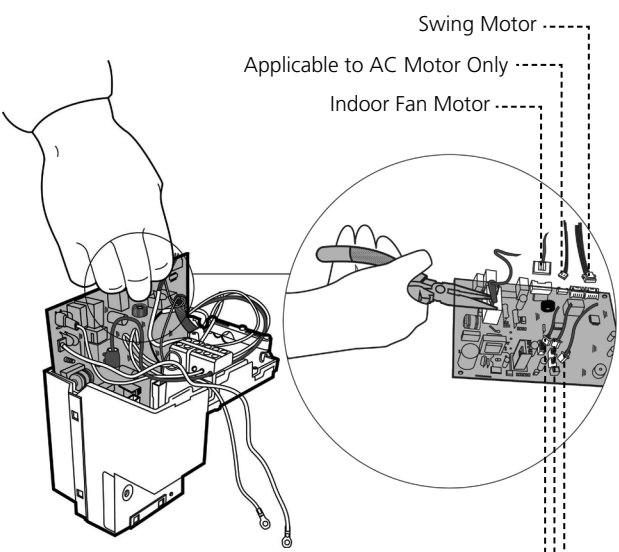
Procedure	Illustration
<p>4) Remove the fixing screw (see CJ_AF_011-1).</p> <p>5) Pull out the Electrical control box along the direction indicated in right image. to remove it (see CJ_AF_011-2).</p>	 <p style="text-align: right;">CJ_AF_011-1</p>  <p style="text-align: center;">CJ_AF_011-2</p>
<p>6) Disconnect the wires. Then remove the electronic main board (see CJ_AF_012).</p>	 <p style="text-align: center;">CJ_AF_012</p>

Note: This section is for reference only. Actual unit appearance may vary.

Procedure

7) Remove the fixing screw, then remove the capacitor of fan motor (see CJ_AF_013).

Illustration

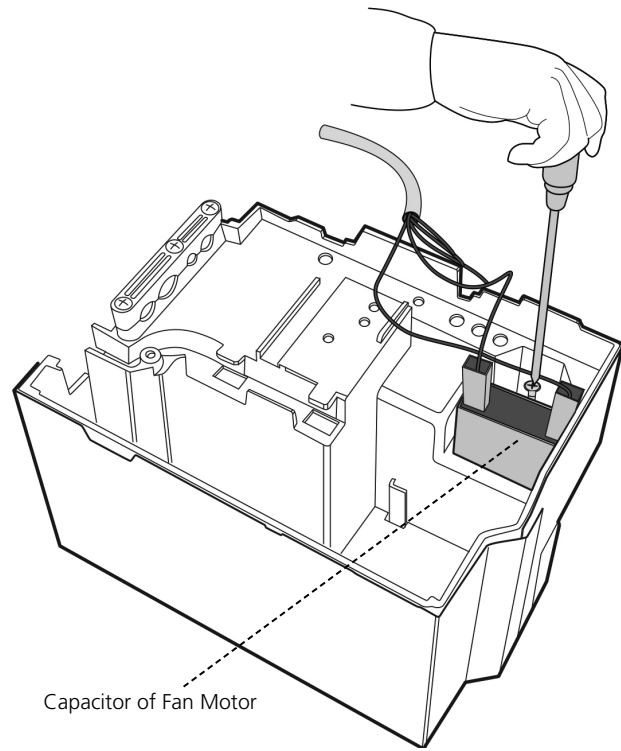

CJ_AF_013

Note: This section is for reference only. Actual unit appearance may vary.

3. Evaporator

Note: Remove the front panel and electrical parts (refer to 1. Front panel and 2. Electrical parts) before disassembling evaporator.

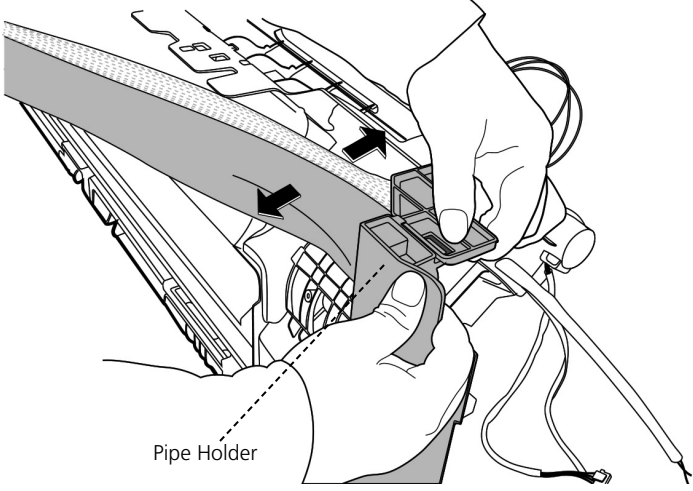
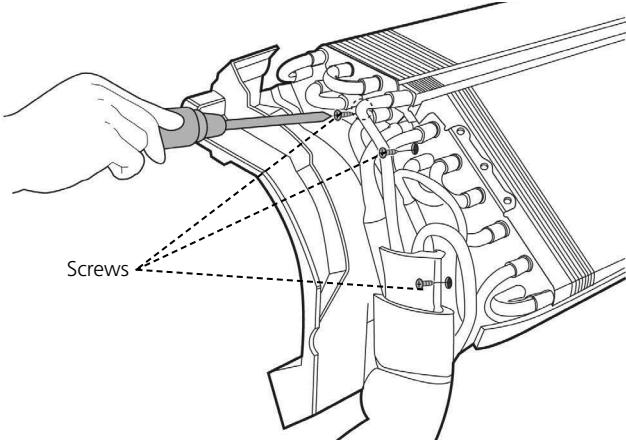
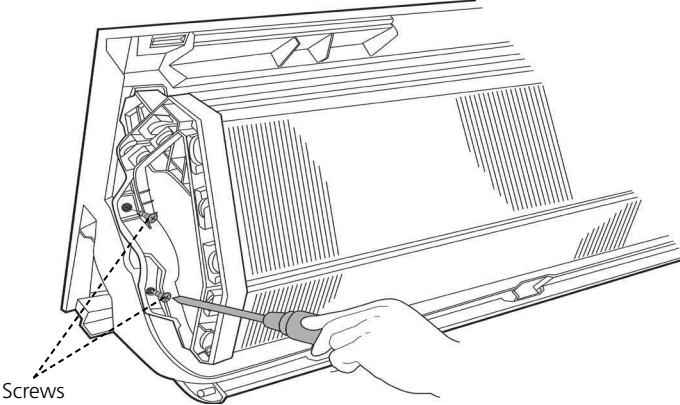
Procedure	Illustration
1) Disassemble the pipe holder located at the rear of the unit (see CJ_AF_014).	 <p>Pipe Holder</p> <p>CJ_AF_014</p>
2) Remove the screws on the evaporator located at the fixed plate (see CJ_AF_015).	 <p>Screws</p> <p>CJ_AF_015</p>
3) Remove the two screws on the evaporator located at the base of the bearing side (see CJ_AF_016).	 <p>Screws</p> <p>CJ_AF_016</p>

Note: This section is for reference only. Actual unit appearance may vary.

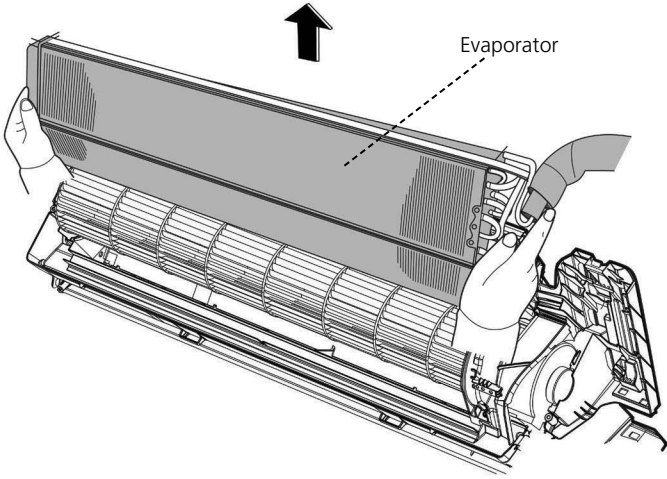
Procedure	Illustration
4) Pull out the evaporator (see CJ_AF_017).	 <p data-bbox="970 862 1109 896">CJ_AF_017</p>

Note: This section is for reference only. Actual unit appearance may vary.

4. Fan motor and fan

Note: Remove the front panel, electrical parts and evaporator (refer to 1. Front panel, 2. Electrical parts, and 3. Evaporator). before disassembling fan motor and fan.

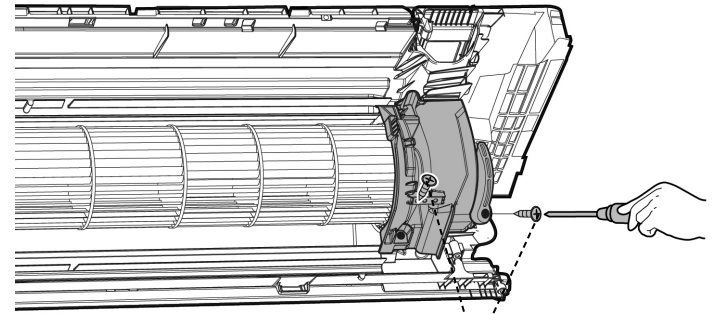
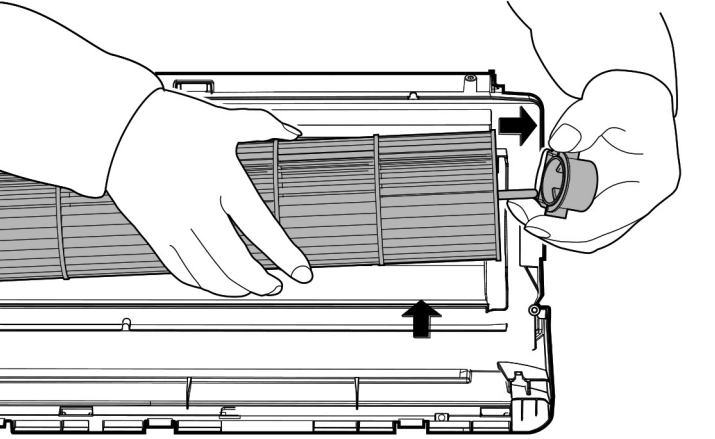
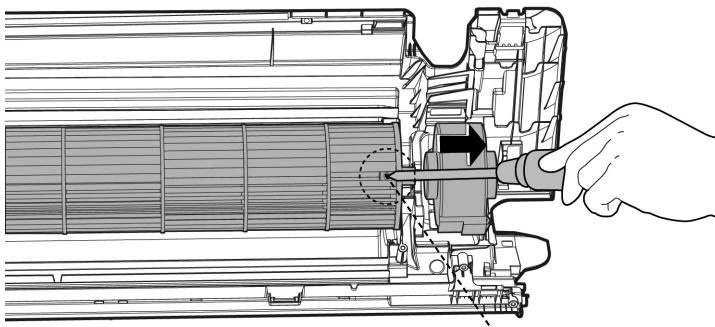
Procedure	Illustration
1) Remove the two screws and remove the fixing board of the fan motor (see CJ_AF_018).	 <p data-bbox="1117 840 1189 862">Screws</p> <p data-bbox="965 862 1109 896">CJ_AF_018</p>
2) Remove the Bearing sleeve(see CJ_AF_019).	 <p data-bbox="965 1456 1109 1489">CJ_AF_019</p>
3) Remove the fixing screw (see Fig CJ_AF_020). 4) Pull out the fan motor and fan assembly from the side.	 <p data-bbox="1197 1892 1316 1915">Fixing Screw</p> <p data-bbox="965 1915 1109 1948">CJ_AF_020</p>

Note: This section is for reference only. Actual unit appearance may vary.

5. Step motor

Note: Remove the front panel and electrical parts (refer to 1. Front panel, 2. Electrical parts) before disassembling step motor.

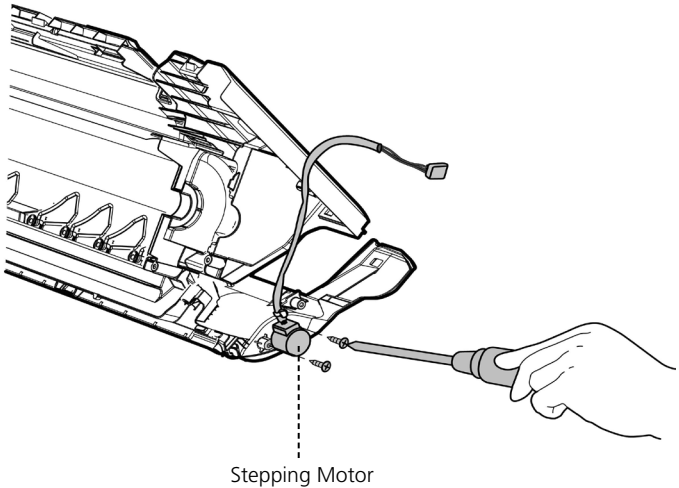
Procedure	Illustration
1) Remove the two screws, then remove the stepping motor (see CJ_AF_021).	 <p data-bbox="932 913 1078 936">Stepping Motor</p> <p data-bbox="970 1003 1107 1034">CJ_AF_021</p>

Note: This section is for reference only. Actual unit appearance may vary.

2.2 Outdoor unit

1. Panel Plate

MOAA31-09CN1-NB8; MOAA31-09CN1-BB8; MOAA30-09CN1-NB6; MOAA31-12CN1-NB8; MOAA31-12CN1-BB8

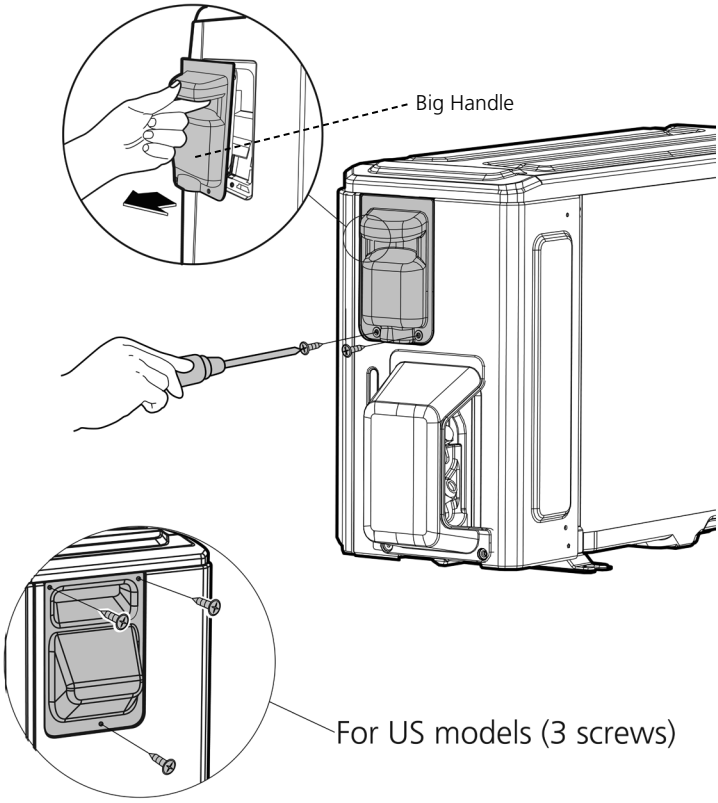
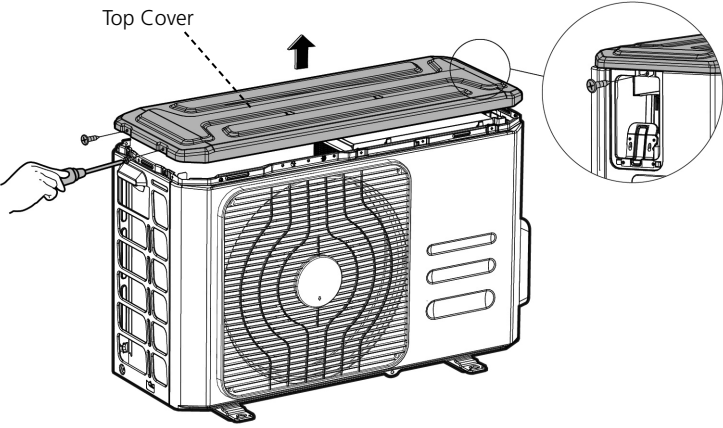
Procedure	Illustration
<p>1) Turn off the air conditioner and the power breaker.</p> <p>2) Remove the screws of the big handle and then remove the big handle (2 screws) (see CJ_AA30_001).</p>	 <p>Big Handle</p> <p>For US models (3 screws)</p> <p>CJ_AA30_001</p>
<p>3) Remove the screws of the top cover and then remove the top cover (3 screws). One of the screws is located underneath the big handle (see CJ_AA30_002).</p>	 <p>Top Cover</p> <p>CJ_AA30_002</p>

Note: This section is for reference only. Actual unit appearance may vary.

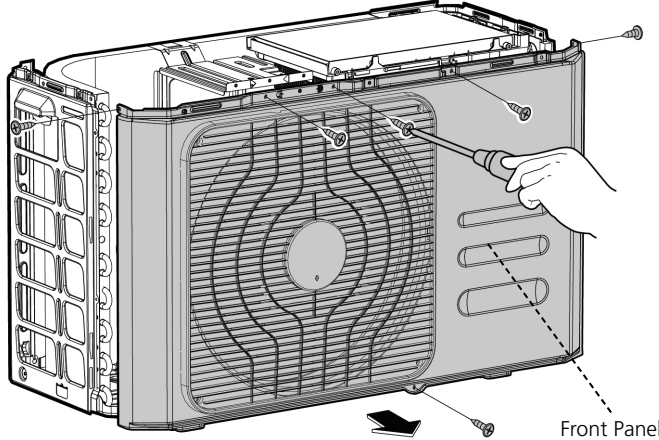
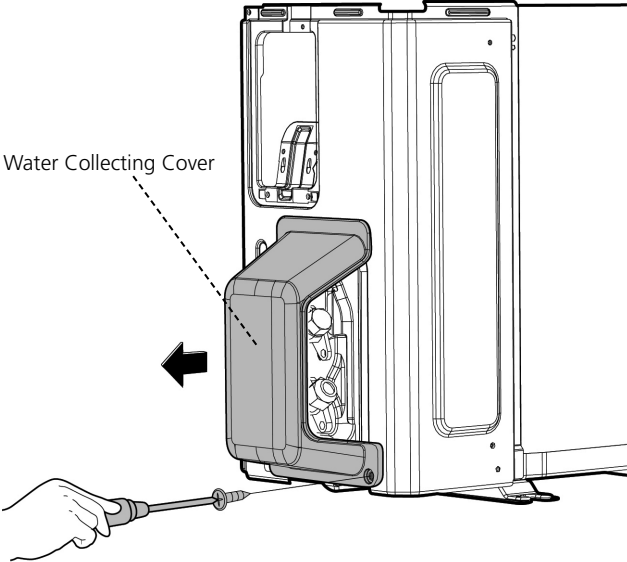
Procedure	Illustration
<p>4) Remove the screws of the front panel and then remove the front panel (6 screws) (see CJ_AA30_003).</p>	 <p>CJ_AA30_003</p>
<p>5) Remove the screws of water collecting cover (1 screw) (see CJ_AA30_004).</p>	 <p>CJ_AA30_004</p>

Note: This section is for reference only. Actual unit appearance may vary.

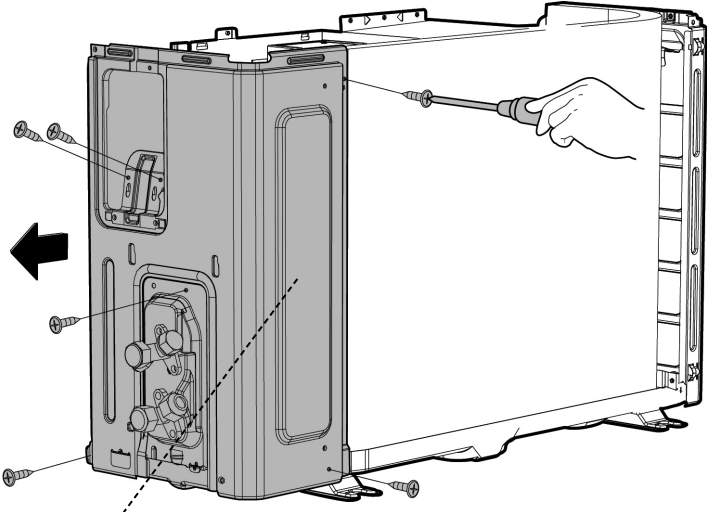
Procedure	Illustration
<p>6) Remove the screws of the right panel and then remove the right panel (6 screws) (see CJ_AA30_005).</p>	 <p>The Right Panel CJ_AA30_005</p>

Note: This section is for reference only. Actual unit appearance may vary.

MOAB31-12CN1-BB8; MOAB32-12CN1-NB8; MOAB31-12CN1-NB8

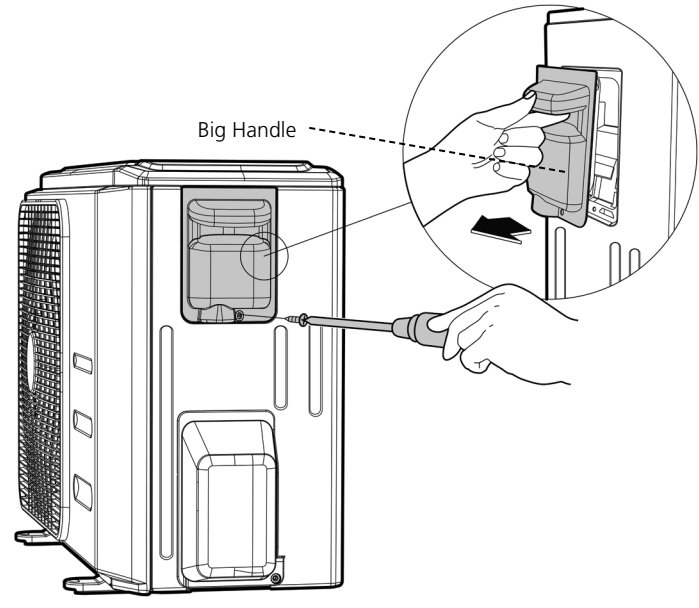
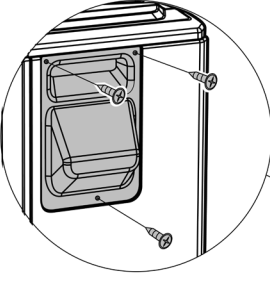
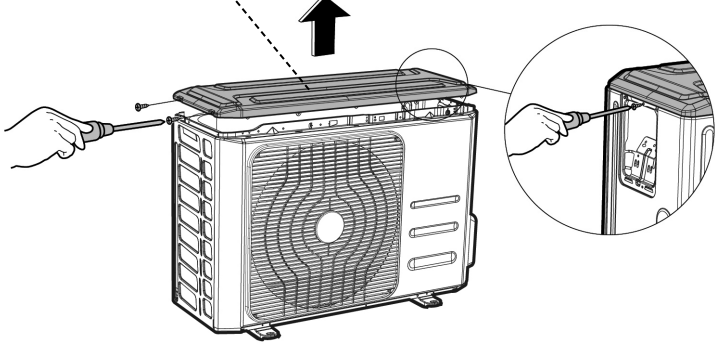
Procedure	Illustration
<p>1) Turn off the air conditioner and the power breaker.</p> <p>2) Remove the screws of the big handle and then remove the big handle (1 screws) (see CJ_AB30_001).</p>	 <p>Big Handle</p>  <p>For US models (3 screws)</p> <p>CJ_AB30_001</p>
<p>3) Remove the screws of the top cover and then remove the top cover (3 screws). One of the screws is located underneath the big handle (see CJ_AB30_002).</p>	 <p>Top Cover</p> <p>CJ_AB30_002</p>

Note: This section is for reference only. Actual unit appearance may vary.

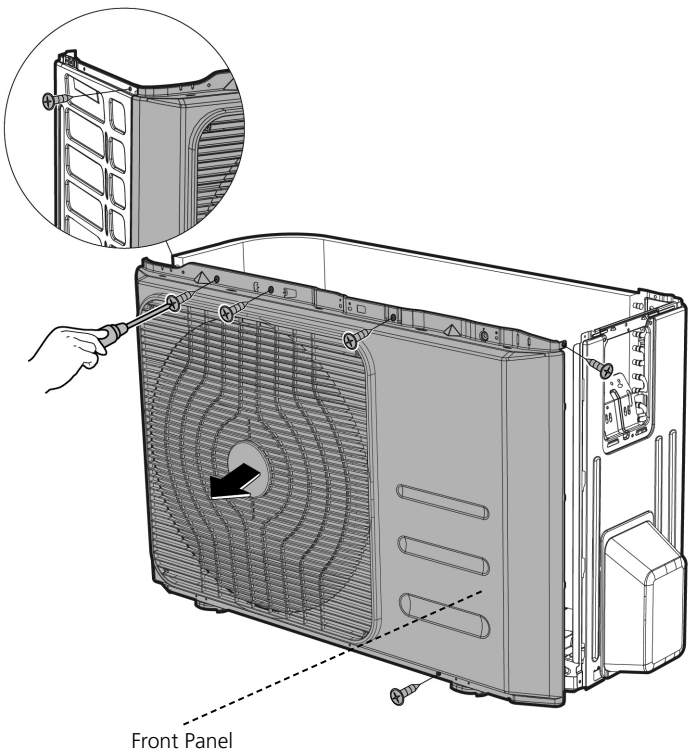
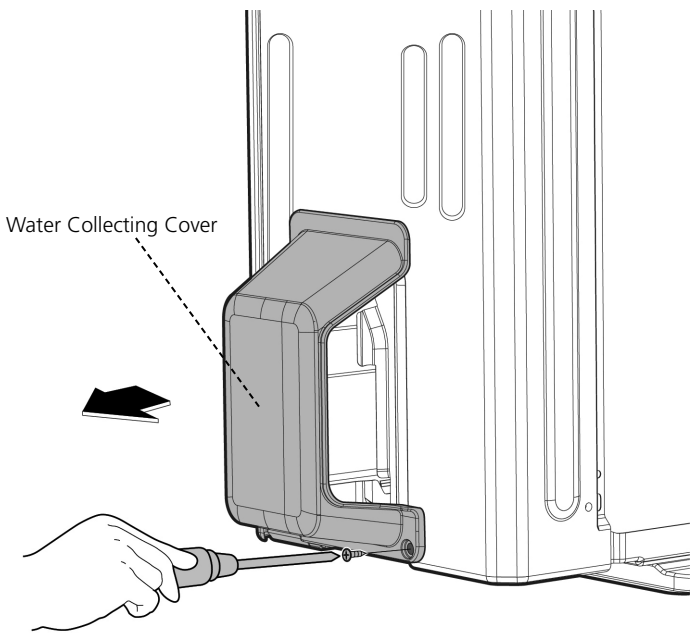
Procedure	Illustration
<p>4) Remove the screws of the front panel and then remove the front panel (6 screws) (see CJ_AB30_003).</p>	 <p>Front Panel</p> <p>CJ_AB30_003</p>
<p>5) Remove the screws of water collecting cover (1 screw) (see CJ_AB30_004).</p>	 <p>Water Collecting Cover</p> <p>CJ_AB30_004</p>

Note: This section is for reference only. Actual unit appearance may vary.

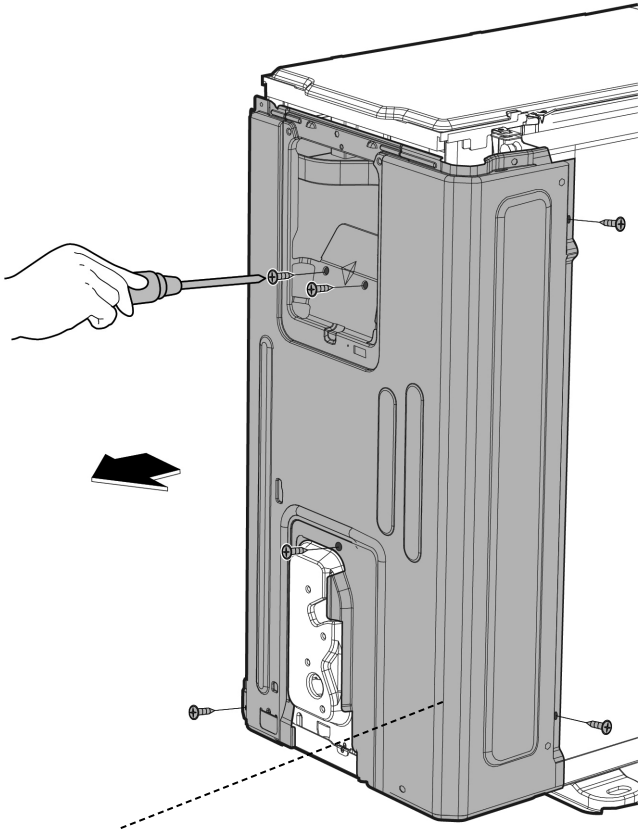
Procedure	Illustration
<p>6) Remove the screws of the right panel and then remove the right panel (5 screws) (see CJ_AB30_005).</p>	 <p data-bbox="801 1191 906 1218">Right Panel</p> <p data-bbox="928 1245 1104 1272">CJ_AB30_005</p>

Note: This section is for reference only. Actual unit appearance may vary.

MOBA31-18CN1-NB8; MOBA32-18CN1-NB8

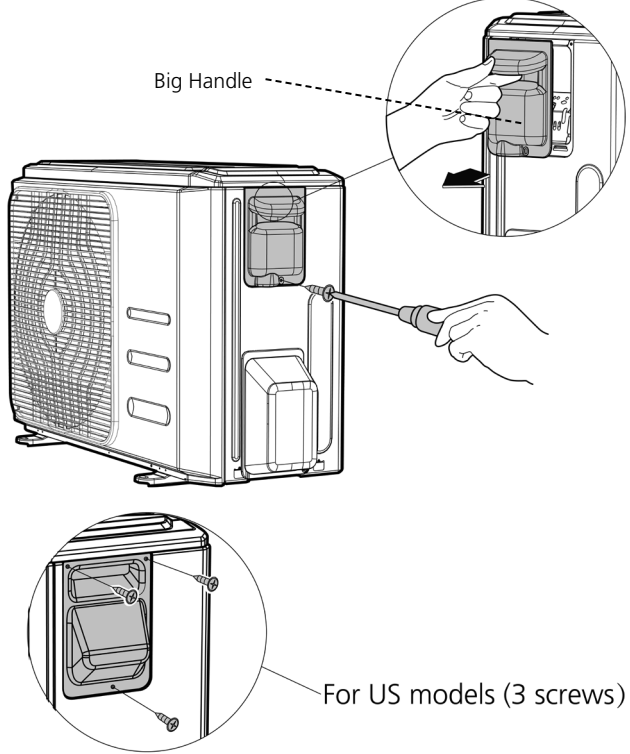
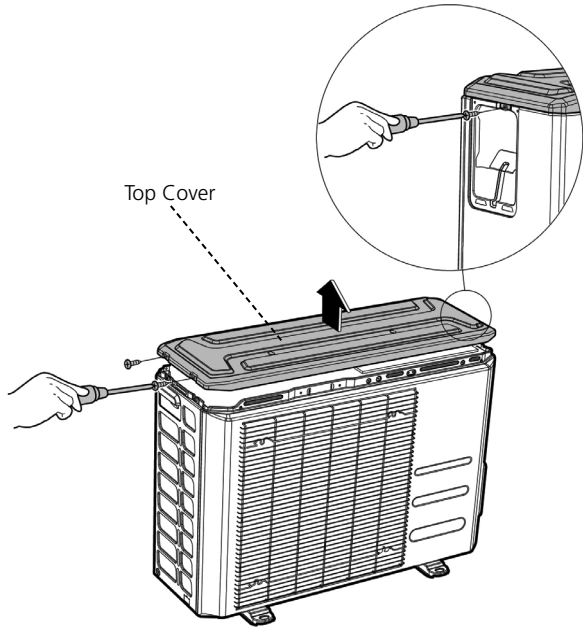
Procedure	Illustration
<p>1) Turn off the air conditioner and the power breaker.</p> <p>2) Remove the screws of the big handle and then remove the big handle (1 screws) (see CJ_BA30_001).</p>	 <p>Big Handle</p> <p>For US models (3 screws)</p> <p>CJ_BA30_001</p>
<p>3) Remove the screws of the top cover and then remove the top cover (3 screws). One of the screws is located underneath the big handle (see CJ_BA30_002).</p>	 <p>Top Cover</p> <p>CJ_BA30_002</p>

Note: This section is for reference only. Actual unit appearance may vary.

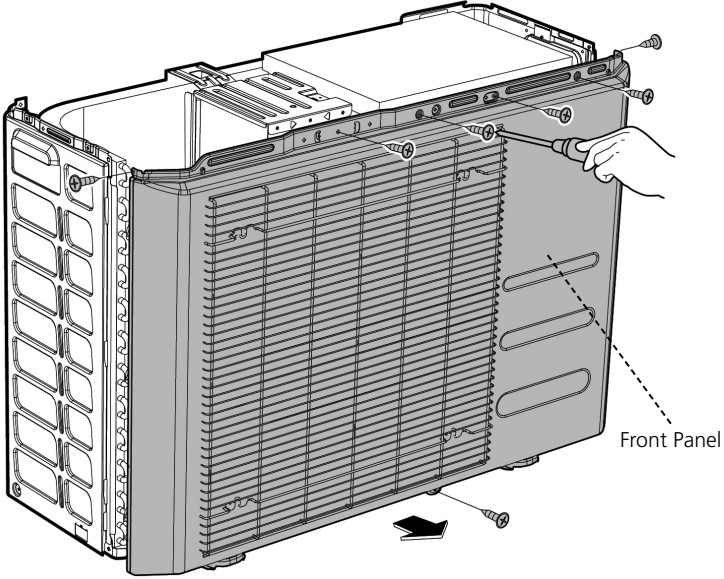
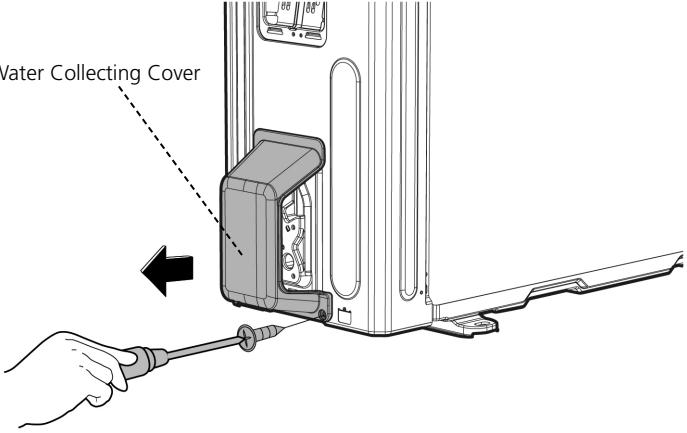
Procedure	Illustration
<p>4) Remove the screws of the front panel and then remove the front panel (7 screws) (see CJ_BA30_003).</p>	 <p style="text-align: center;">CJ_BA30_003</p>
<p>5) Remove the screws of water collecting cover (1 screw) (see CJ_BA30_004).</p>	 <p style="text-align: center;">CJ_BA30_004</p>

Note: This section is for reference only. Actual unit appearance may vary.

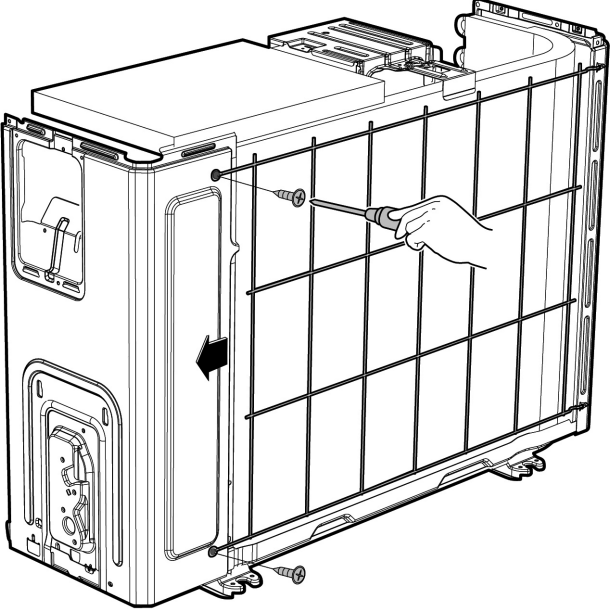
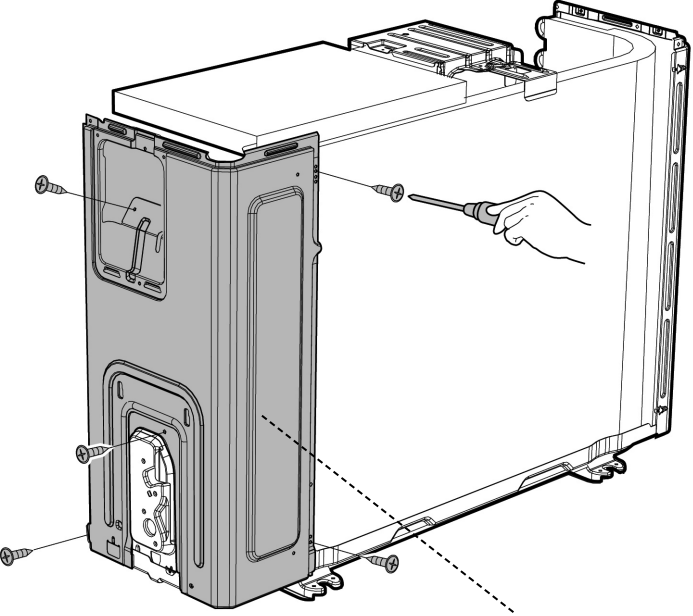
Procedure	Illustration
<p>6) Remove the screws of the rear net and then remove the rear net (2 screws) (see CJ_BA30_005).</p>	 <p style="text-align: center;">CJ_BA30_005</p>
<p>7) Remove the screws of the right panel and then remove the right panel (5 screws) (see CJ_BA30_006).</p>	 <p style="text-align: center;">CJ_BA30_006</p>

Note: This section is for reference only. Actual unit appearance may vary.

MOCA30-24CN1-NB8W

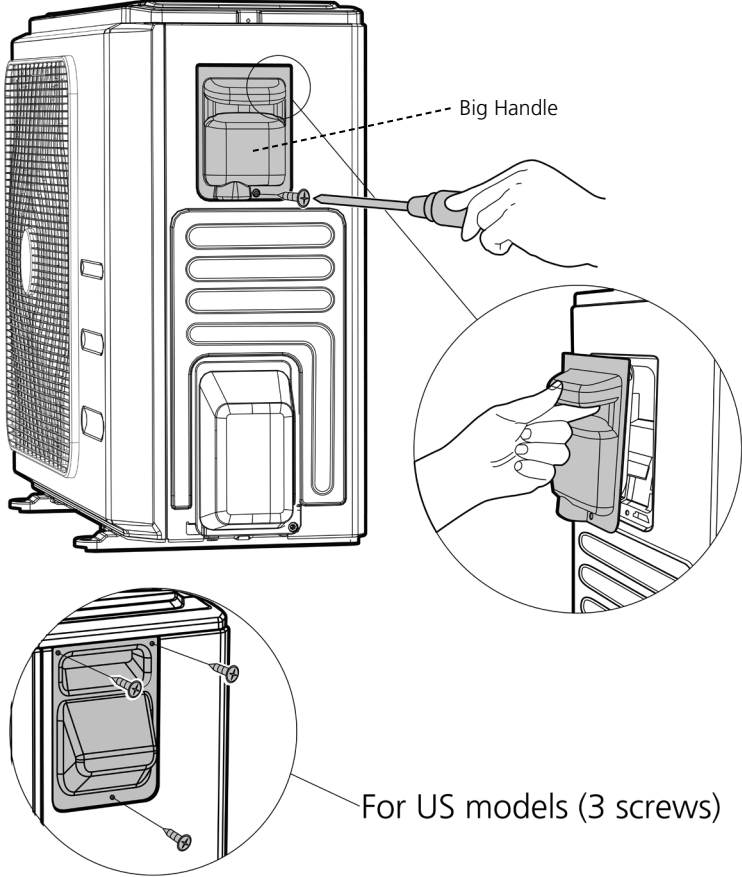
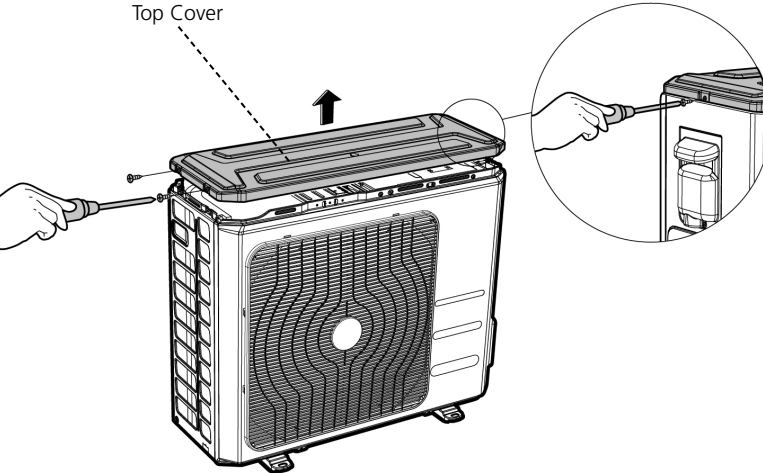
Procedure	Illustration
<p>1) Turn off the air conditioner and the power breaker.</p> <p>2) Remove the screws of the big handle and then remove the big handle (1 screws) (see CJ_CA30_001).</p>	 <p>Big Handle</p> <p>For US models (3 screws)</p> <p>CJ_CA30_001</p>
<p>3) Remove the screws of the top cover and then remove the top cover (3 screws). One of the screws is located underneath the big handle (see CJ_CA30_002).</p>	 <p>Top Cover</p> <p>CJ_CA30_002</p>

Note: This section is for reference only. Actual unit appearance may vary.

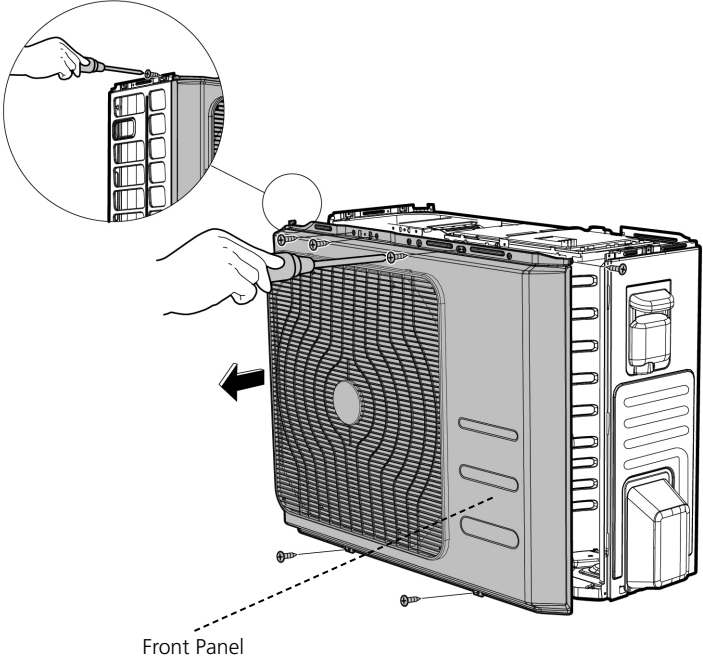
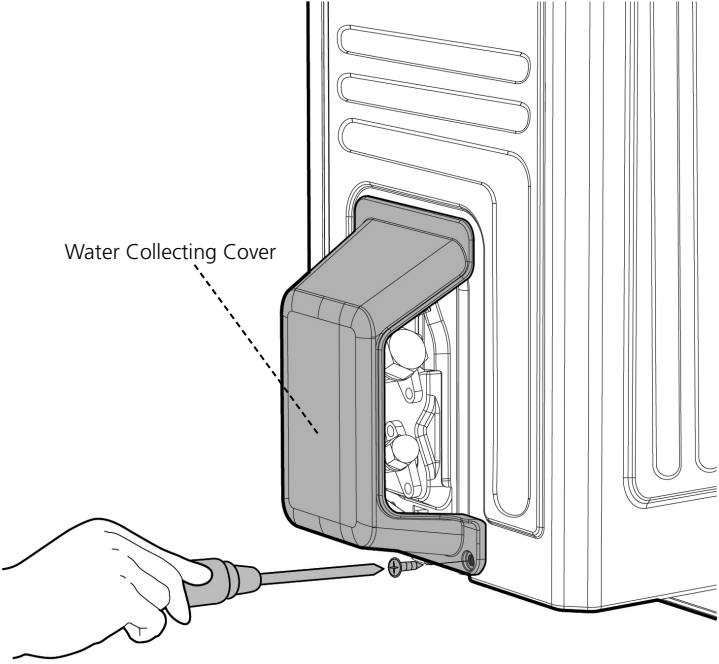
Procedure	Illustration
<p>4) Remove the screws of the front panel and then remove the front panel (7 screws) (see CJ_CA30_003).</p>	 <p style="text-align: center;">CJ_CA30_003</p>
<p>5) Remove the screws of water collecting cover and then remove the water collecting cover (1 screw) (see CJ_CA30_004).</p>	 <p style="text-align: center;">CJ_CA30_004</p>

Note: This section is for reference only. Actual unit appearance may vary.

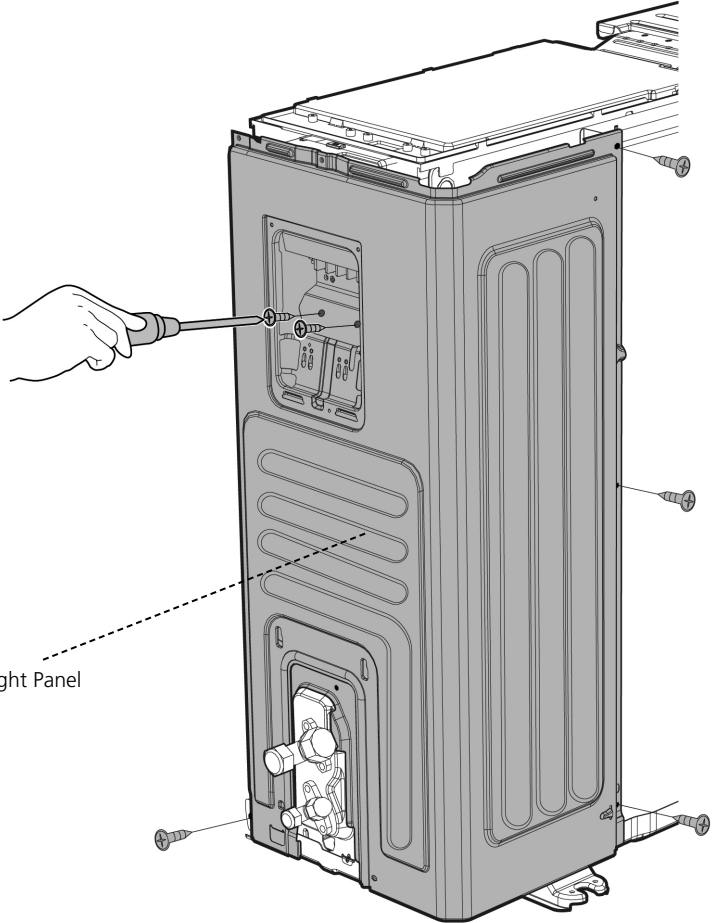
Procedure	Illustration
<p>6) Remove the screws of the right panel and then remove the right panel (6 screws) (see CJ_CA30_005).</p>	 <p>The illustration shows a hand using a screwdriver to remove screws from the right panel of a unit. A dashed line points to the right panel, which is labeled "Right Panel". The unit is shown from a three-quarter view, with the right panel being the focus of the disassembly process. The screws are being removed from the top, middle, and bottom sections of the panel. The unit is labeled "CJ_CA30_005" at the bottom.</p>

Note: This section is for reference only. Actual unit appearance may vary.

2. Fan disassembly

Note: Remove the panel plate and (refer to 1. Panel plate) before disassembling fan.

MOAA31-09CN1-BB8; MOAB31-12CN1-BB8; MOAA31-12CN1-BB8; MOAA30-09CN1-NB6; MOAA31-09CN1-NB8; MOAB32-12CN1-NB8; MOAA31-12CN1-NB8; MOAB31-12CN1-NB8; MOBA31-18CN1-NB8; MOBA32-18CN1-NB8

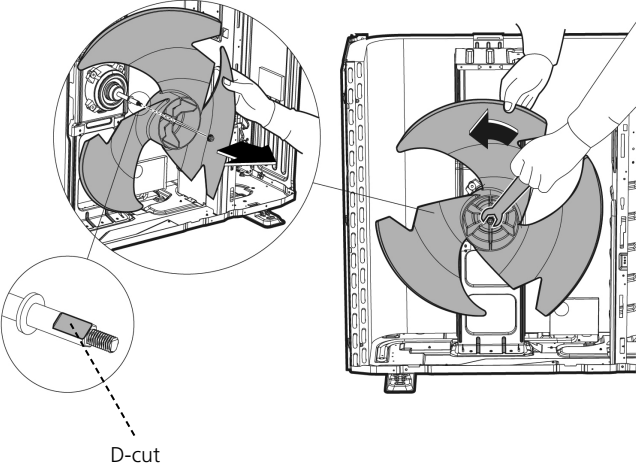
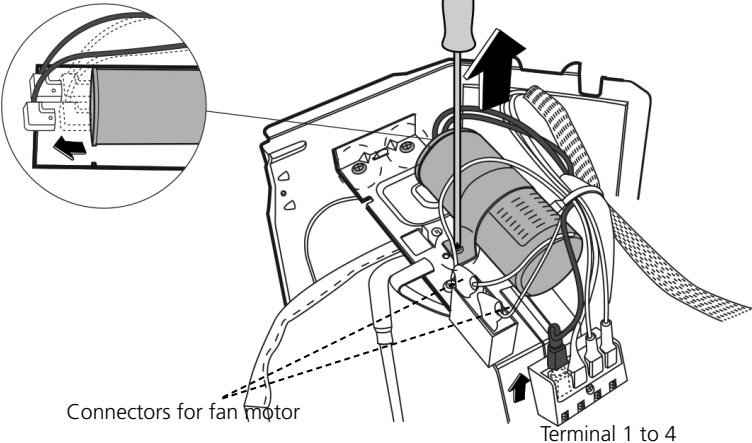
Procedure	Illustration
<p>1) Remove the nut securing the fan with a spanner (see CJ_ODU_001).</p> <p>2) Remove the fan.</p>	 <p style="text-align: center;">CJ_ODU_001</p>
<p>3) Disconnect the connectors for fan motor. (Blue wire, yellow wire, red wire, brown wire and black wire. The blue wire and red wire are on the capacitor. The black wire connects with terminal 4.) (see CJ_ODU_002)</p>	 <p style="text-align: center;">CJ_ODU_002</p>

Note: This section is for reference only. Actual unit appearance may vary.

Procedure

- 4) Remove the fixing screws of the fan motor (4 screws) (see CJ_ODU_003).
- 5) Remove the fan motor.

Illustration

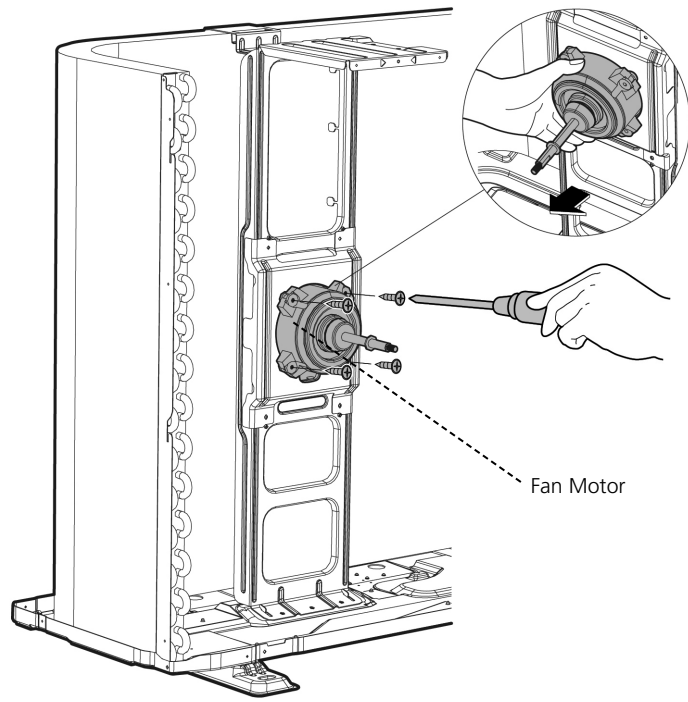

CJ_ODU_003

Note: This section is for reference only. Actual unit appearance may vary.

MOCA30-24CN1-NB8W

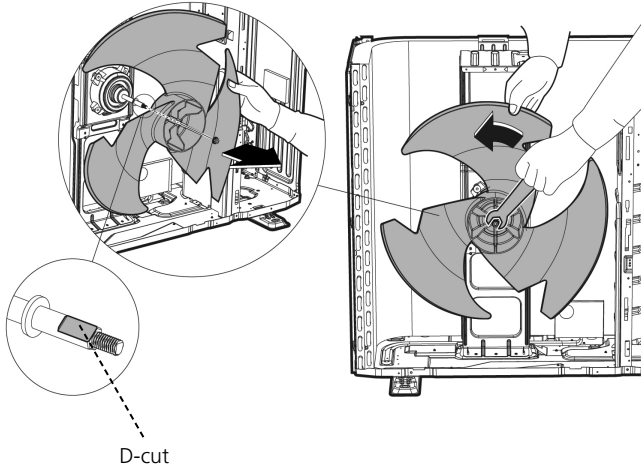
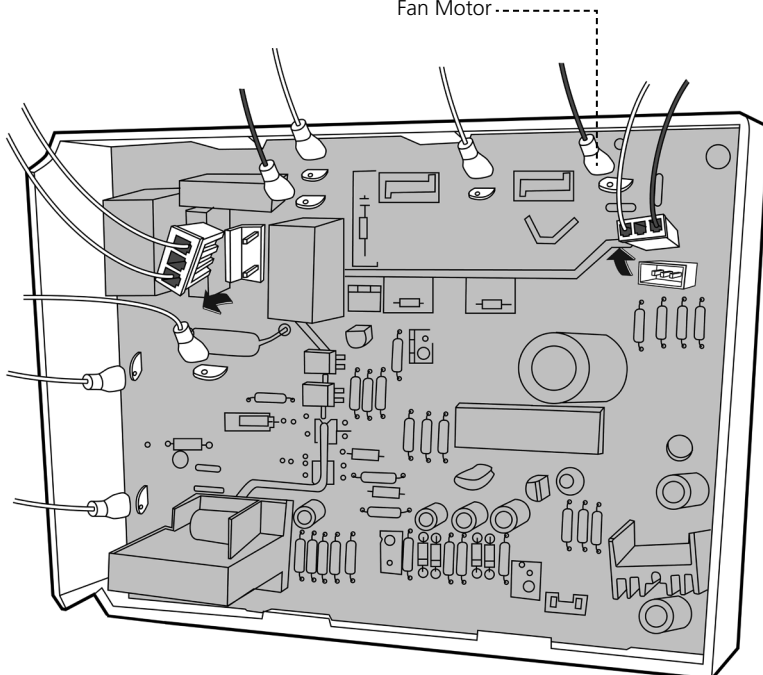
Procedure	Illustration
<p>1) Remove the nut securing the fan with a spanner (see CJ_ODU_004).</p> <p>2) Remove the fan.</p>	 <p style="text-align: center;">CJ_ODU_004</p>
<p>3) Disconnect the connectors for fan motor. (Blue wire, red wire, brown wire and black wire. The blue wire and brown wire are on the capacitor. The black wire connects with a terminal. And the red wire is on the board.) (see CJ_ODU_005)</p>	 <p style="text-align: center;">CJ_ODU_005</p>

Note: This section is for reference only. Actual unit appearance may vary.

Procedure

- 4) Remove the fixing screws of the fan motor (4 screws) (see CJ_ODU_006).
- 5) Remove the fan motor.

Illustration

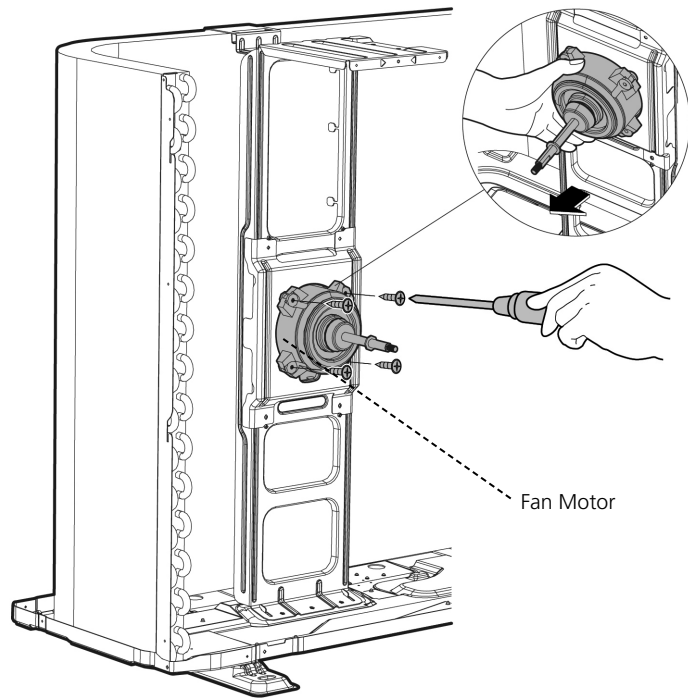

CJ_ODU_006

Note: This section is for reference only. Actual unit appearance may vary.

3. Electrical parts

Note: Remove the air outlet grille(refer to 1. Panel plate) before disassembling electrical parts.

MOAA31-09CN1-BB8; MOAB31-12CN1-BB8; MOAA31-12CN1-BB8; MOAA30-09CN1-NB6; MOAA31-09CN1-NB8; MOAB32-12CN1-NB8; MOAA31-12CN1-NB8; MOAB31-12CN1-NB8; MOBA31-18CN1-NB8; MOBA32-18CN1-NB8

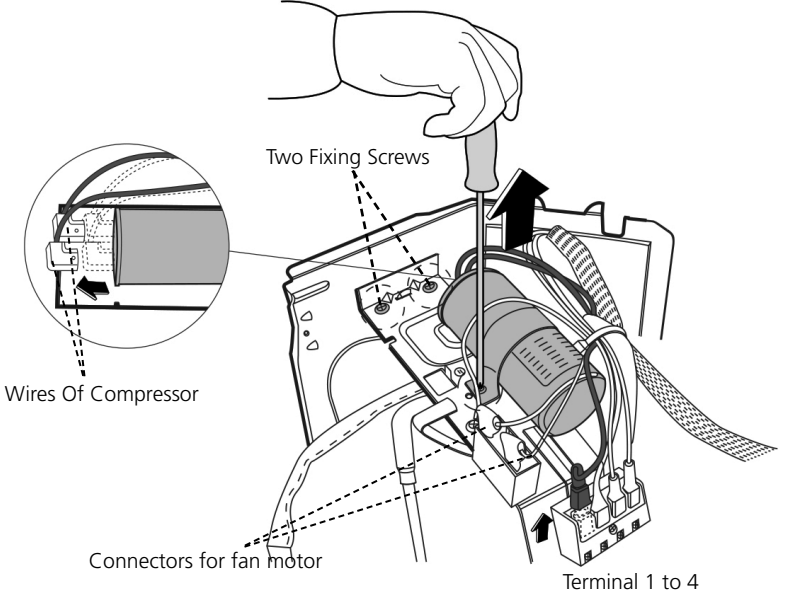
Procedure	Illustration
<ol style="list-style-type: none">1) Remove the two screws fixed the electronic control board (see CJ_ODU_007).2) Disconnect the wires connected to the compressor. (Black wire connects with terminal 1, blue wire and red wire connect with the compressor capacitor) (see CJ_ODU_007)3) Disconnect the wires connected to 4-way valve. (Blue wires on terminal 2&3) (see CJ_ODU_007)4) Remove the fixing screw of the compressor capacitor, then pull it out (see CJ_ODU_007)5) Remove the electrical parts (see CJ_ODU_007)	 <p style="text-align: center;">CJ_ODU_007</p>

Note: This section is for reference only. Actual unit appearance may vary.

MOCA30-24CN1-NB8W

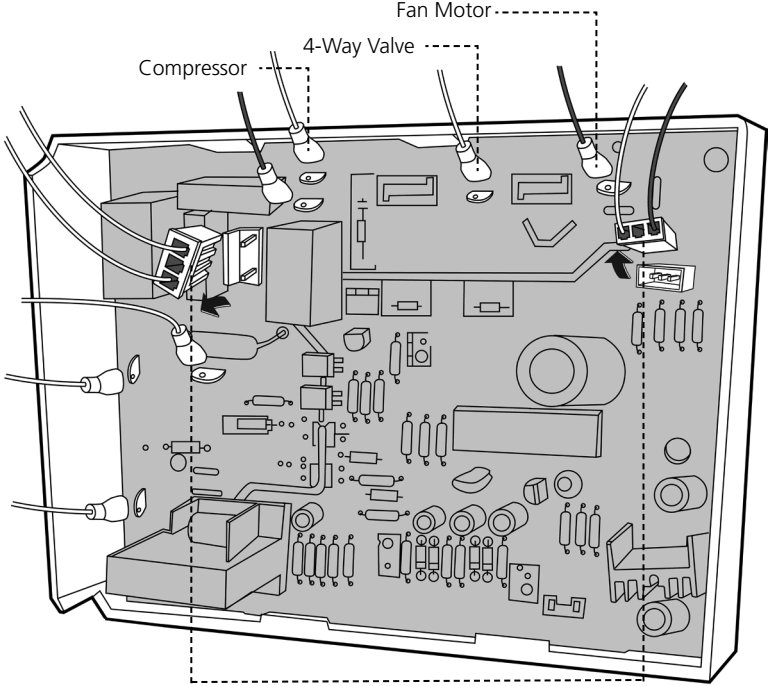
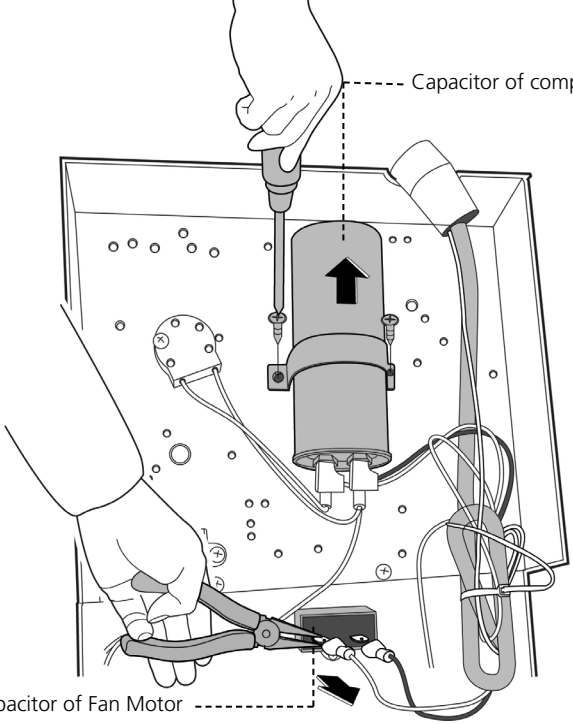
Procedure	Illustration
<p>1) Disconnect the wires connected to the compressor. (Red wire connects with PCB board, others connects with terminals) (see CJ_ODU_008)</p> <p>2) Disconnect the wires connected to 4-way valve. (see CJ_ODU_008)</p> <p>3) Disconnect the wires connected to the transformer. (see CJ_ODU_008)</p> <p>4) Disconnect the other wires connected to terminals. (see CJ_ODU_008)</p> <p>5) Remove the PCB board. (see CJ_ODU_008)</p>	 <p>Compressor</p> <p>4-Way Valve</p> <p>Fan Motor</p> <p>Transformer</p> <p>CJ_ODU_008</p>
<p>6) Remove the screws of the capacitors. (see CJ_ODU_009)</p>	 <p>Capacitor of compressor</p> <p>Capacitor of Fan Motor</p> <p>CJ_ODU_009</p>

Note: This section is for reference only. Actual unit appearance may vary.

4. Sound blanket

⚠ WARNING: Recover refrigerant from the refrigerant circuit before remove the compressor.

Note: Remove the panel plate, electrical parts, and fan assembly (refer to 1. Panel plate, 2. Electrical parts, and 3. Fan assembly) before disassembling sound blanket.

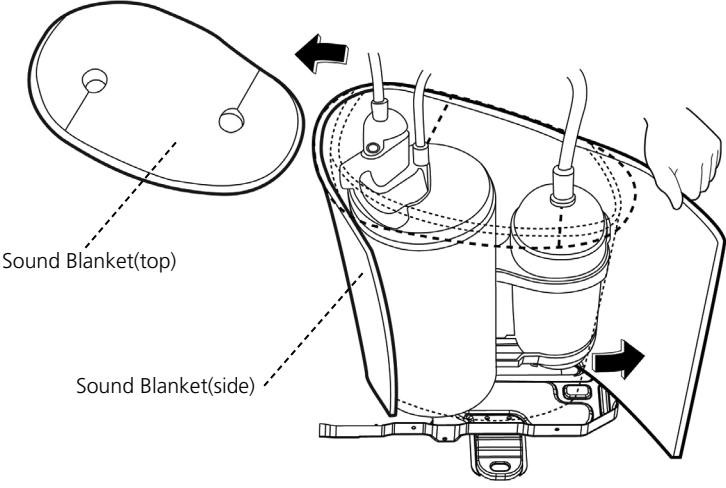
Procedure	Illustration
1) Remove the sound blanket (side and top) (see CJ_ODU_010).	 <p data-bbox="933 1064 1101 1097">CJ_ODU_010</p>

Note: This section is for reference only. Actual unit appearance may vary.

5. Compressor

⚠ WARNING: Recover refrigerant from the refrigerant circuit before remove the compressor.

Note: Remove the panel plate, electrical parts, and fan assembly (refer to 1. Panel plate, 2. Electrical parts, and 3. Fan assembly) before disassembling compressor.

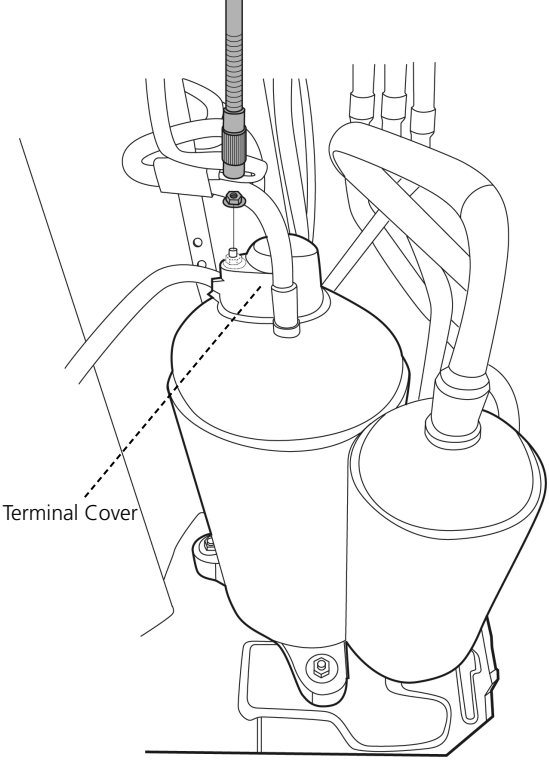
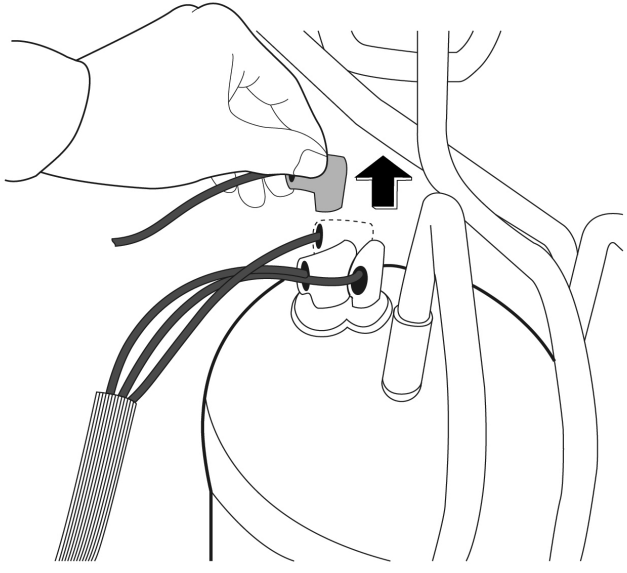
Procedure	Illustration
<p>1) Remove the flange nut of terminal cover and remove the terminal cover (see CJ_ODU_011).</p>	 <p>The diagram shows a top-down view of the compressor assembly. A dashed line points to a terminal cover on the left side of the unit. The cover is a cylindrical component with a flange nut at the top. The compressor is connected to various pipes and hoses.</p> <p style="text-align: center;">CJ_ODU_011</p>
<p>2) Disconnect the connectors (see CJ_ODU_012).</p>	 <p>The diagram shows a close-up of a hand using a tool to disconnect an electrical connector from the compressor. An upward-pointing arrow indicates the direction of the tool's movement. The connector is a multi-pin plug that fits into a socket on the compressor's terminal block.</p> <p style="text-align: center;">CJ_ODU_012</p>

Note: This section is for reference only. Actual unit appearance may vary.

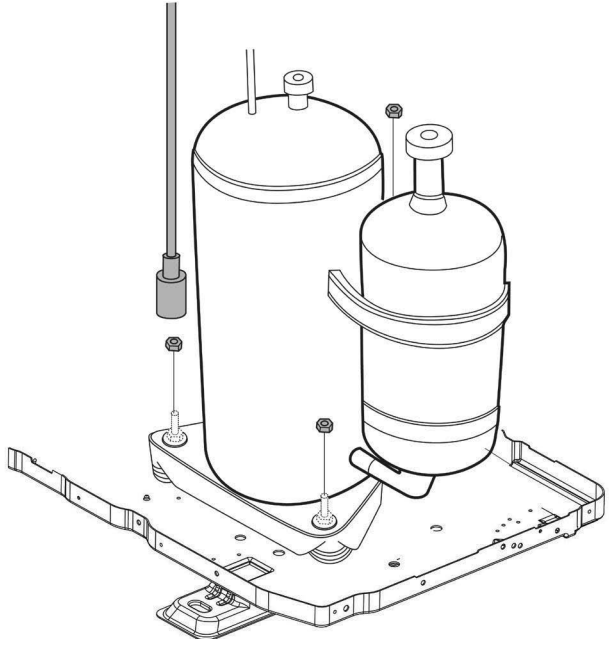
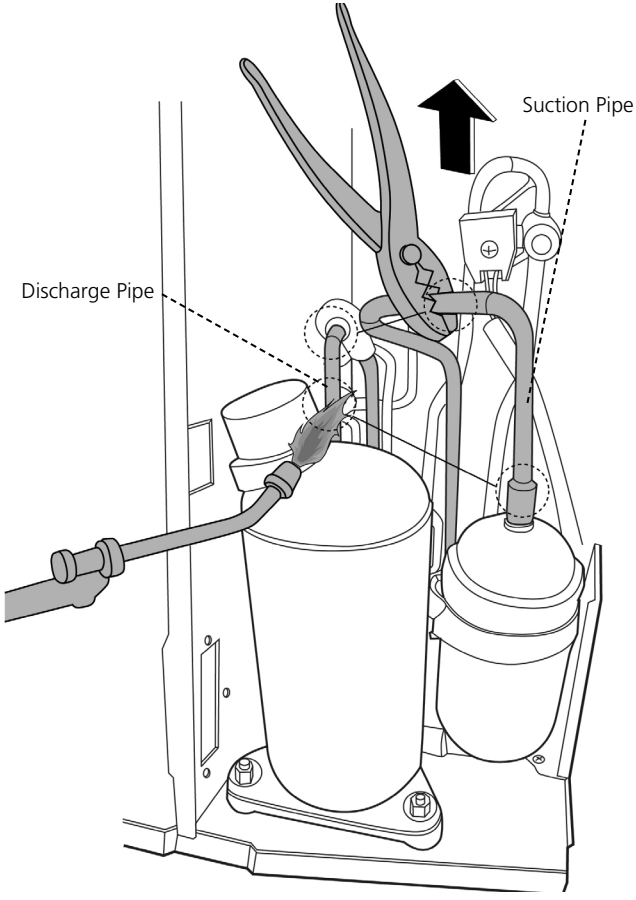
Procedure	Illustration
<p>3) Remove the hex nuts and washers securing the compressor, located on the bottom plate (see CJ_ODU_013).</p>	 <p style="text-align: center;">CJ_ODU_013</p>
<p>4) Heat up the brazed parts and then remove the the discharge pipe and the suction pipe (see CJ_ODU_014).</p> <p>5) Lift the compressor from the base pan assembly with pliers.</p>	 <p style="text-align: center;">CJ_ODU_014</p>

Note: This section is for reference only. Actual unit appearance may vary.

Troubleshooting

Contents

1.	Safety Caution	55
2.	General Troubleshooting	56
3.	Error Diagnosis and Troubleshooting Without Error Code.....	57
	3.1 Remote maintenance.....	57
	3.2 Field maintenance	58
4.	Quick Maintenance by Error Code.....	59
5.	Troubleshooting by Error Code.....	64
	5.1 Common Check Procedures.....	64
	5.2 E0(EEPROM parameter error)	65
	5.3 E1(Indoor and outdoor unit communication error) (only for MSAFD-24CRN1-NB8W)	66
	5.4 E2 (Zero crossing detection error diagnosis and solution)	67
	5.5 E3 (Fan speed has been out of control diagnosis and solution).....	68
	5.6 E4/E5 (Open circuit or short circuit of temperature sensor diagnosis and solution)	70
	5.7 E7 (Indoor PCB /Display board communication error)	71
	5.8 EC (Refrigerant Leakage Detection diagnosis and solution)	72

1. Safety Caution

WARNING

Electricity remains in capacitors even when the power supply is off.
Ensure the capacitors are fully discharged before troubleshooting.

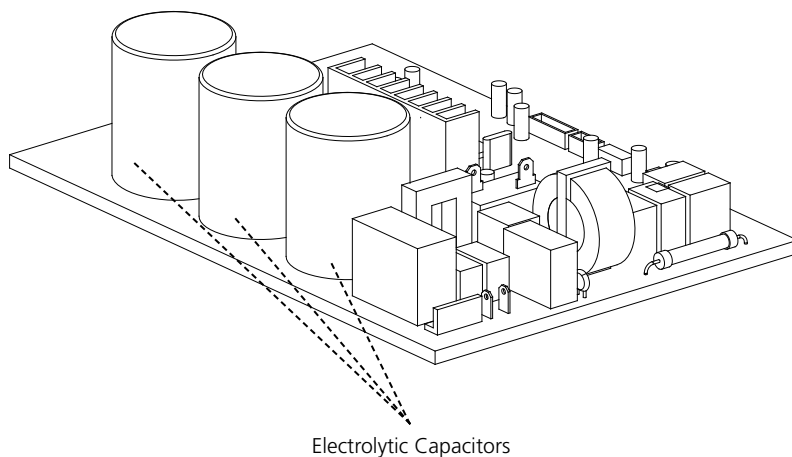

For other models, connect discharge resistance (approx. 100Ω 40W) or a soldering iron plug between the positive and negative terminals of the electrolytic capacitor. The terminals are located on the bottom surface of the outdoor PCB.

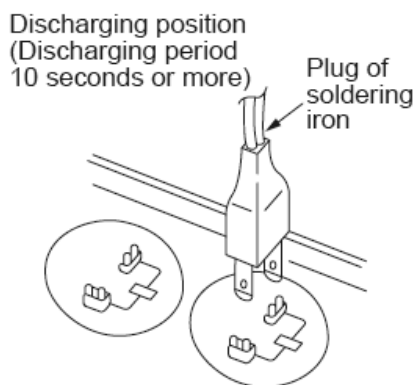

Note: This picture is for reference only. Actual appearances may vary.

2. General Troubleshooting

2.1 Error Display (Indoor Unit)

When the indoor unit encounters a recognized error, the indicator light will flash in a corresponding series, the timer display may turn on or begin flashing, and an error code will be displayed. These error codes are described in the following table:

Indicator flashes	Timer Display	Display	Error Information	Solution
1	OFF	E0	Indoor unit EEPROM parameter error	Page 65
2	OFF	E1	Indoor / outdoor units communication error (only for MSAFD-24CRN1-NB8W)	Page 66
3	OFF	E2	Zero-crossing signal detection error	Page 67
4	OFF	E3	The indoor fan speed is operating outside of the normal range	Page 68
5	OFF	E4	Indoor room temperature sensor T1 is in open circuit or has short circuited	Page 70
6	OFF	E5	Evaporator coil temperature sensor T2 is in open circuit or has short circuited	Page 70
9	OFF	E7	Indoor PCB /Display board communication error	Page 71
7	OFF	EC	Refrigerant leak detected	Page 72

For other errors:

The display board may show a garbled code or a code undefined by the service manual. Ensure that this code is not a temperature reading.

Troubleshooting:

Test the unit using the remote control. If the unit does not respond to the remote, the indoor PCB requires replacement. If the unit responds, the display board requires replacement.

3. Error Diagnosis and Troubleshooting Without Error Code

WARNING

Be sure to turn off unit before any maintenance to prevent damage or injury.

3.1 Remote maintenance

SUGGESTION: When troubles occur, please check the following points with customers before field maintenance.

	Problem	Solution
1	Unit will not start	Page 60-61
2	The power switch is on but fans will not start	Page 60-61
3	The temperature on the display board cannot be set	Page 60-61
4	Unit is on but the wind is not cold(hot)	Page 60-61
5	Unit runs, but shortly stops	Page 60-61
6	The unit start ups and stops frequently	Page 60-61
7	Unit runs continuously but insufficient cooling(heating)	Page 60-61
8	Cool can not change to heat	Page 60-61
9	Unit is noisy	Page 60-61

3.2 Field maintenance

	Problem	Solution
1	Unit will not start	Page 62-63
2	Compressor will not start but fans run	Page 62-63
3	Compressor and condenser (outdoor) fan will not start	Page 62-63
4	Evaporator (indoor) fan will not start	Page 62-63
5	Condenser (Outdoor) fan will not start	Page 62-63
6	Unit runs, but shortly stops	Page 62-63
7	Compressor short-cycles due to overload	Page 62-63
8	High discharge pressure	Page 62-63
9	Low discharge pressure	Page 62-63
10	High suction pressure	Page 62-63
11	Low suction pressure	Page 62-63
12	Unit runs continuously but insufficient cooling	Page 62-63
13	Too cool	Page 62-63
14	Compressor is noisy	Page 62-63
15	Horizontal louver can not revolve	Page 62-63

4. Quick Maintenance by Error Code

If you do not have the time to test whether specific parts are faulty, you can directly change the required parts according to the error code.

You can find the parts to replace by error code in the following table.

Part requiring replacement	Error Code							
	E0	E1	E2	E3	E4	E5	E7	E8
Indoor PCB	✓	✓	✓	✓	✓	✓	✓	✓
Outdoor PCB	x	✓	x	x	x	x	x	✓
Indoor fan motor	x	x	x	✓	x	x	x	x
Outdoor fan motor	x	x	x	x	x	x	x	x
Temperature sensor	x	x	x	x	✓	✓	x	x
T2 Sensor	x	x	x	x	x	x	x	✓
T3 Sensor	x	x	x	x	x	x	x	x
Additional refrigerant	x	x	x	x	x	x	x	✓
Display board	x	x	x	x	x	x	✓	x
Compressor	x	x	x	x	x	x	x	✓
Capacitor of compressor	x	x	x	x	x	x	x	✓
Capacitor of fan motor	x	x	x	x	x	x	x	✓

1.Remote Maintenance	Electrical Circuit					Refrigerant Circuit								
Possible causes of trouble	Power failure	The main power tripped	Loose connections	Faulty transformer	The voltage is too high or too low	The remote control is powered off	Broken remote control	Dirty air filter	Dirty condenser fins	The setting temperature is higher/lower than the room's (cooling/heating)	The ambient temperature is too high/low when the mode is cooling/heating	Fan mode	SILENCE function is activated (optional function)	Frosting and defrosting frequently
Unit will not start	☆	☆	☆	☆										
The power switch is on but fans will not start			☆	☆	☆									
The temperature on the display board cannot be set						☆	☆							
Unit is on but the wind is not cold(hot)										☆	☆	☆		
Unit runs, but shortly stops					☆					☆	☆			
The unit starts up and stops frequently					☆						☆			☆
Unit runs continuously but insufficient cooling(heating)								☆	☆	☆	☆		☆	
Cool can not change to heat														
Unit is noisy														
Test method / remedy	Test voltage	Close the power switch	Inspect connections - tighten	Change the transformer	Test voltage	Replace the battery of the remote control	Replace the remote control	Clean or replace	Clean	Adjust the setting temperature	Turn the AC later	Adjust to cool mode	Turn off SILENCE function.	Turn the AC later

Others	
Check heat load	Heavy load condition
Tighten bolts or screws	Loosen hold down bolts and / or screws
Close all the windows and doors	Bad airproof
Remove the obstacles	The air inlet or outlet of either unit is blocked
Reconnect the power or press ON/OFF button on remote control to restart	Interference from cell phone towers and remote boosters
Remove them	Shipping plates remain attached

2.Field Maintenance	Electrical Circuit														
Possible causes of trouble	Power failure	Blown fuse or varistor	Loose connections	Shorted or broken wires	Safety device opens	Faulty thermostat / room temperature sensor	Wrong setting place of temperature sensor	Faulty transformer	Shorted or open capacitor	Faulty magnetic contactor for compressor	Faulty magnetic contactor for fan	Low voltage	Faulty stepping motor	Shorted or grounded compressor	Shorted or grounded fan motor
Unit will not start	☆	☆	☆	☆	☆			☆							
Compressor will not start but fans run				☆		☆			☆	☆				☆	
Compressor and condenser (outdoor) fan will not start				☆		☆				☆					
Evaporator (indoor) fan will not start				☆					☆		☆				☆
Condenser (Outdoor) fan will not start				☆		☆			☆		☆				☆
Unit runs, but shortly stops										☆		☆			
Compressor short-cycles due to overload										☆		☆			
High discharge pressure															
Low discharge pressure															
High suction pressure															
Low suction pressure															
Unit runs continuously but insufficient cooling															
Too cool						☆	☆								
Compressor is noisy															
Horizontal louver can not revolve			☆	☆									☆		
Test method / remedy	Test voltage	Inspect fuse type & size	Inspect connections - tighten	Test circuits with tester	Test continuity of safety device	Test continuity of thermostat / sensor & wiring	Place the temperature sensor at the central of the air inlet grille	Check control circuit with tester	Check capacitor with tester	Test continuity of coil & contacts	Test continuity of coil & contacts	Test voltage	Replace the stepping motor	Check resistance with multimeter	Check resistance with multimeter

Refrigerant Circuit											Others
Replace the compressor											Compressor stuck
Leak test											Shortage of refrigerant
Replace restricted part											Restricted liquid line
Clean or replace											Dirty air filter
Clean coil											Dirty evaporator coil
Check fan											Insufficient air through evaporator coil
Change charged refrigerant volume											Overcharge of refrigerant
Clean condenser or remove obstacle											Dirty or partially blocked condenser
Purge, evacuate and recharge											Air or incompressible gas in refrigerant cycle
Remove obstruction to air flow											Short cycling of condensing air
Remove obstruction in air or water flow											High temperature condensing medium
Remove obstruction in air or water flow											Insufficient condensing medium
Replace compressor											Broken compressor internal parts
Test compressor efficiency											Inefficient compressor
Replace valve											Expansion valve obstructed
Replace valve											Expansion valve or capillary tube closed completely
Replace valve											Leaking power element on expansion valve
Fix feeler bulb											Poor installation of feeler bulb
Check heat load											Heavy load condition
Tighten bolts or screws											Loosen hold down bolts and / or screws
Remove them											Shipping plates remain attached
Choose AC of larger capacity or add the number of AC											Poor choices of capacity
Rectify piping so as not to contact each other or with external plate											Contact of piping with other piping or external plate

5. Troubleshooting by Error Code

5.1 Common Check Procedures

5.1.1 Temperature Sensor Check

Disconnect the temperature sensor from PCB, measure the resistance value with a tester.

Temperature Sensors.

Room temp.(T1) sensor,

Indoor coil temp.(T2) sensor,

Outdoor coil temp.(T3) sensor,

Outdoor ambient temp.(T4) sensor,

Measure the resistance value of each winding by using the multi-meter.

5.2 E0 (EEPROM parameter error)

Description: Indoor or outdoor PCB main chip does not receive feedback from EEPROM chip.

Recommended parts to prepare:

- Indoor PCB
- Outdoor PCB

Troubleshooting and repair:

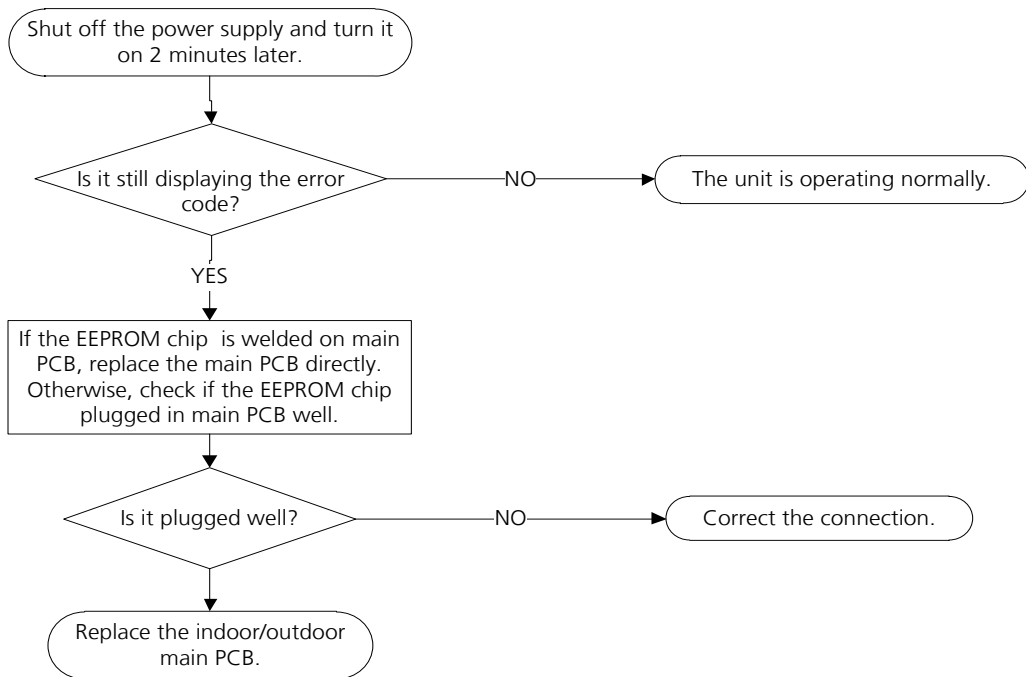

Remarks:

The location of the EEPROM chip on the indoor and outdoor PCB is shown in the following two images:

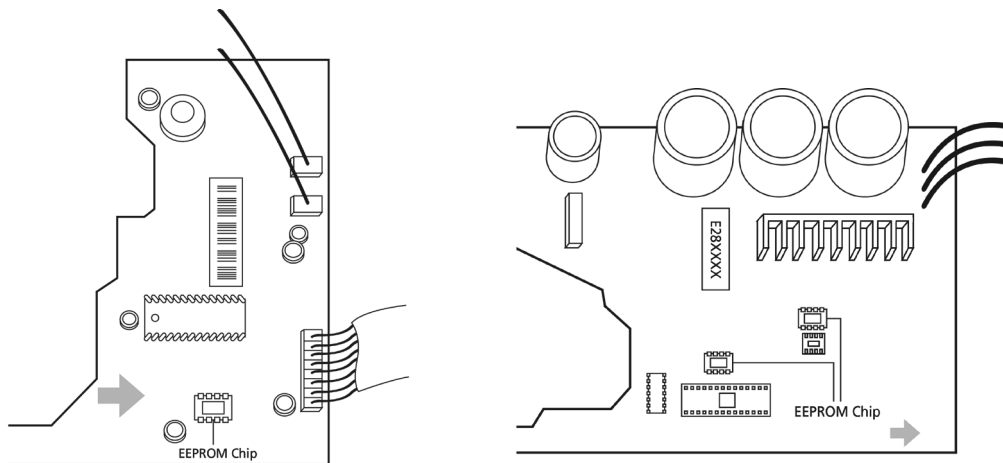

Note: These images are for reference only.

5.3 E1 (Indoor and outdoor unit communication error) (only for MSAFD-24CRN1-NB8W)

Description: The indoor unit has not received feedback from the outdoor unit for 110 seconds, four consecutive times.

Recommended parts to prepare:

- Indoor PCB
- Outdoor PCB
- Reactor

Troubleshooting and repair:

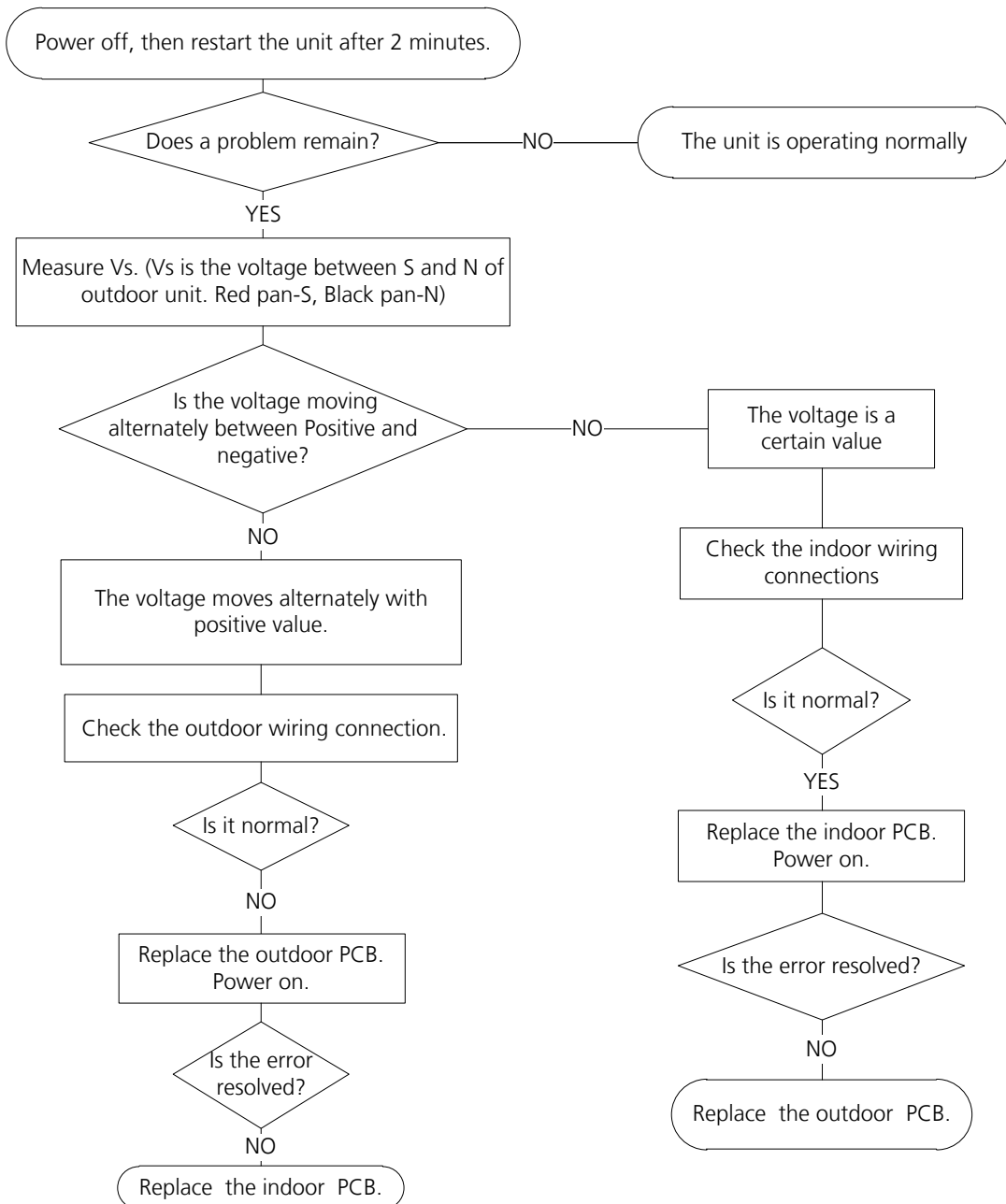

5.4 E2 (Zero crossing detection error diagnosis and solution)

Description: When PCB does not receive zero crossing signal feedback for 4 minutes or the zero crossing signal time interval is abnormal.

Recommended parts to prepare:

- Connection mistake
- PCB faulty

Troubleshooting and repair:

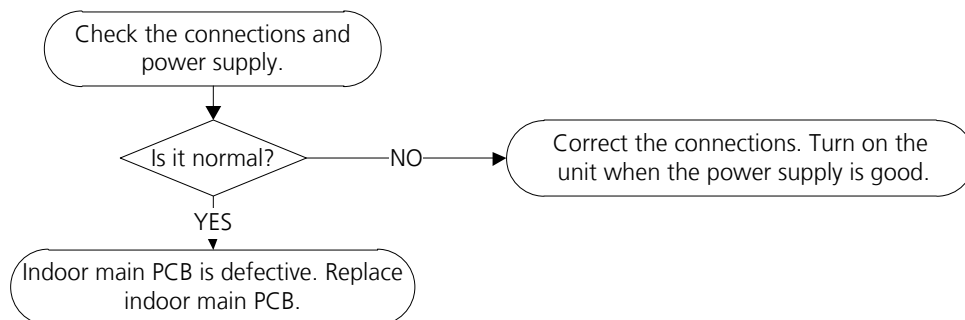

5.5 E3(Fan speed has been out of control diagnosis and solution)

Description: When indoor fan speed keeps too low (300RPM) for certain time, the unit will stop and the LED will display the failure.

Recommended parts to prepare:

- Wiring mistake
- Faulty fan assembly'y faulty
- Faulty fan motor
- Faulty PCB

Troubleshooting and repair:

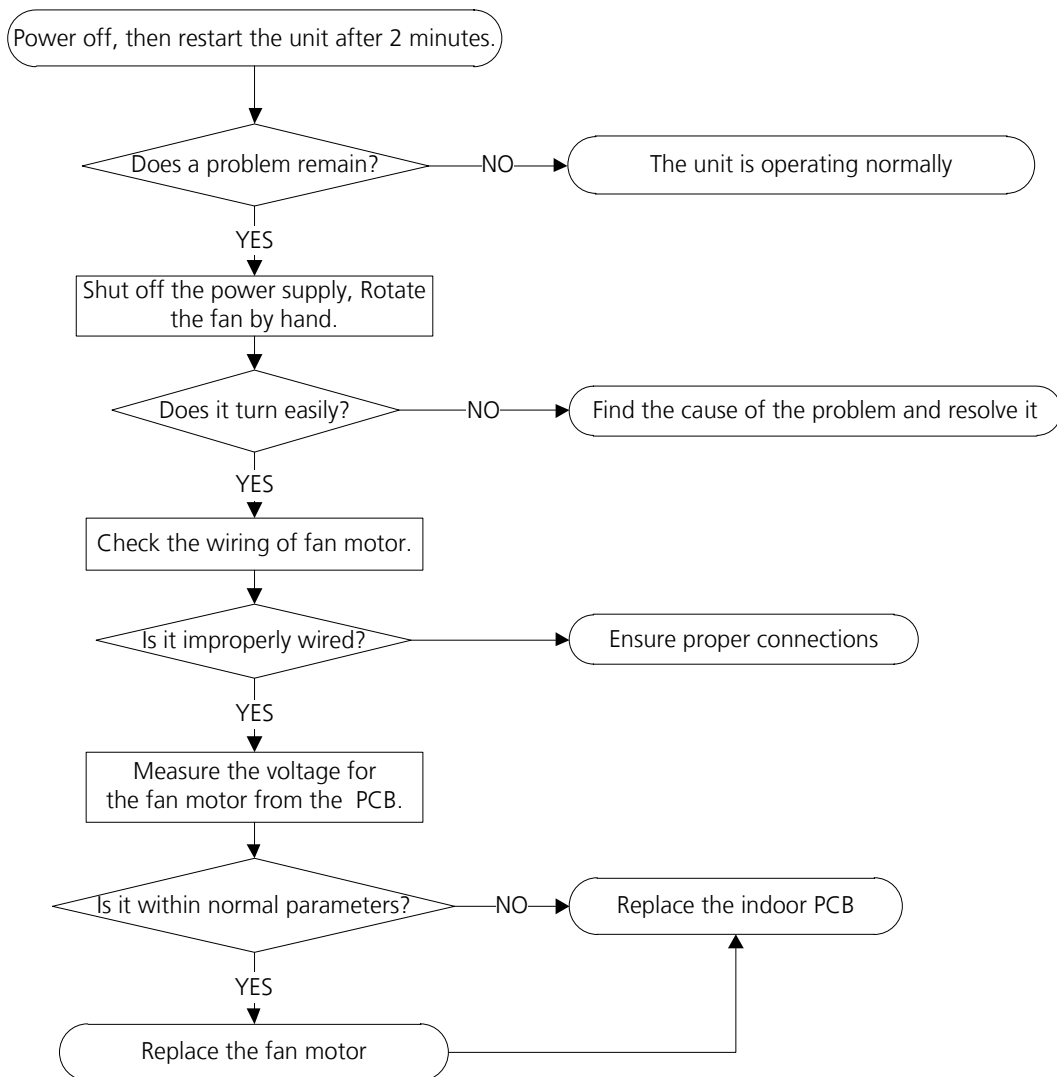

Index:

1. Indoor AC Fan Motor

Power on and set the unit running in fan mode at high fan speed. After running for 15 seconds, measure the voltage of pin1 and pin2. If the value of the voltage is less than 100V(208~240V power supply) or 50V(115V power supply), the PCB must has problems and need to be replaced.

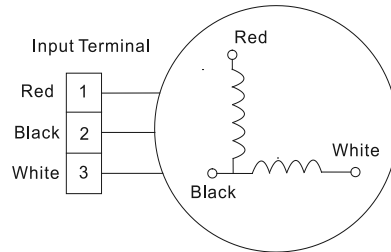

5.6 E4/E5 (Open circuit or short circuit of temperature sensor diagnosis and solution)

Description: If the sampling voltage is lower than 0.06V or higher than 4.94V, the LED will display the failure.

Recommended parts to prepare:

- Wiring mistake
- Faulty sensor
- Faulty PCB

Troubleshooting and repair:

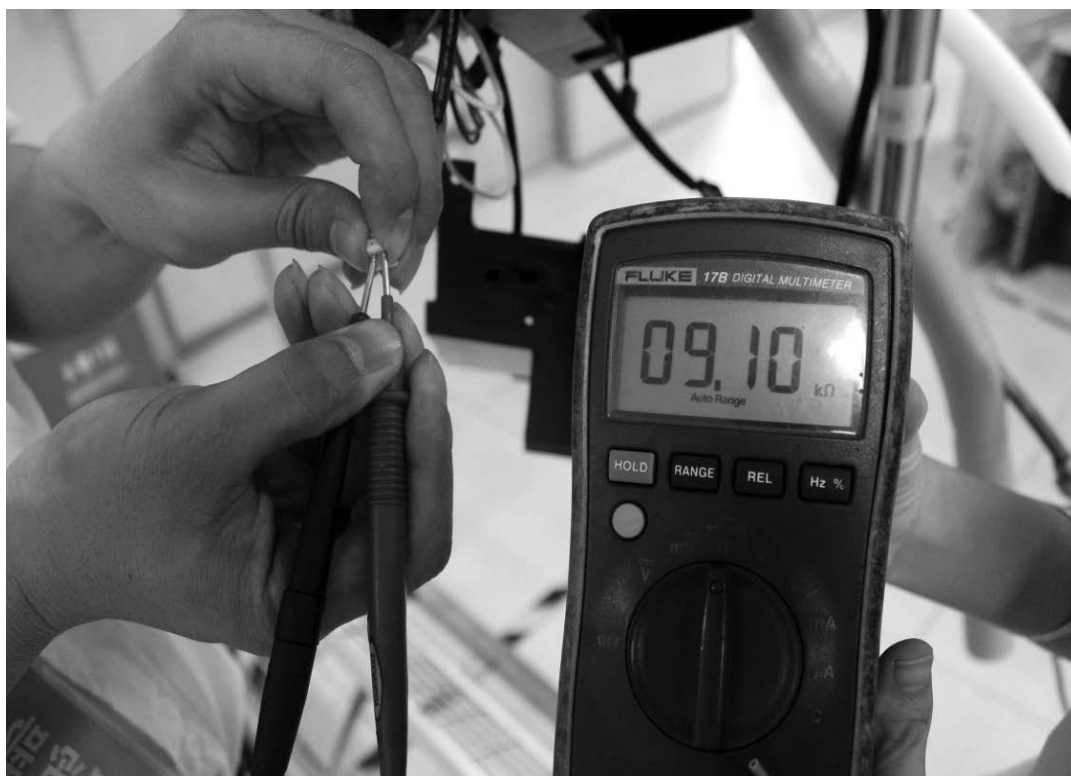
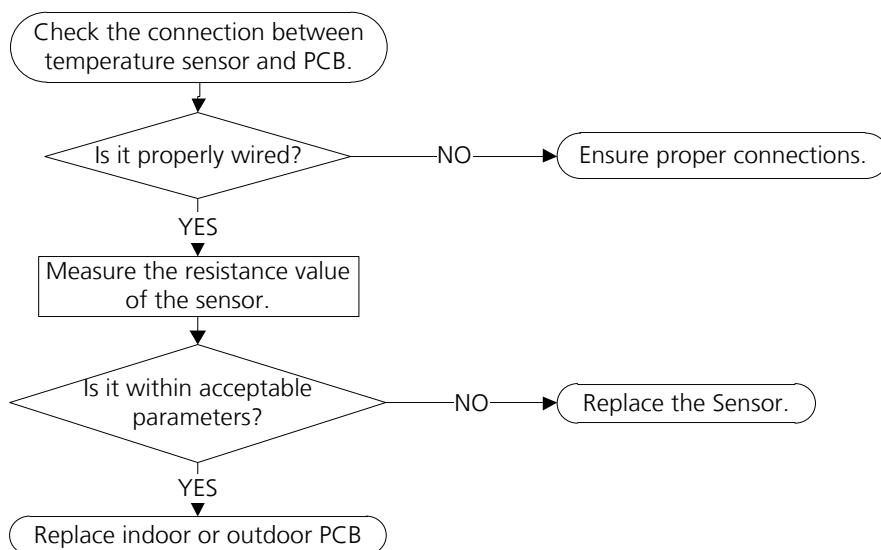

5.7 E7 (Indoor PCB /Display board communication error)

Description: Indoor PCB does not receive feedback from Display board.

Recommended parts to prepare:

- Wiring mistake
- Faulty PCB
- Display board malfunction

Troubleshooting and repair:

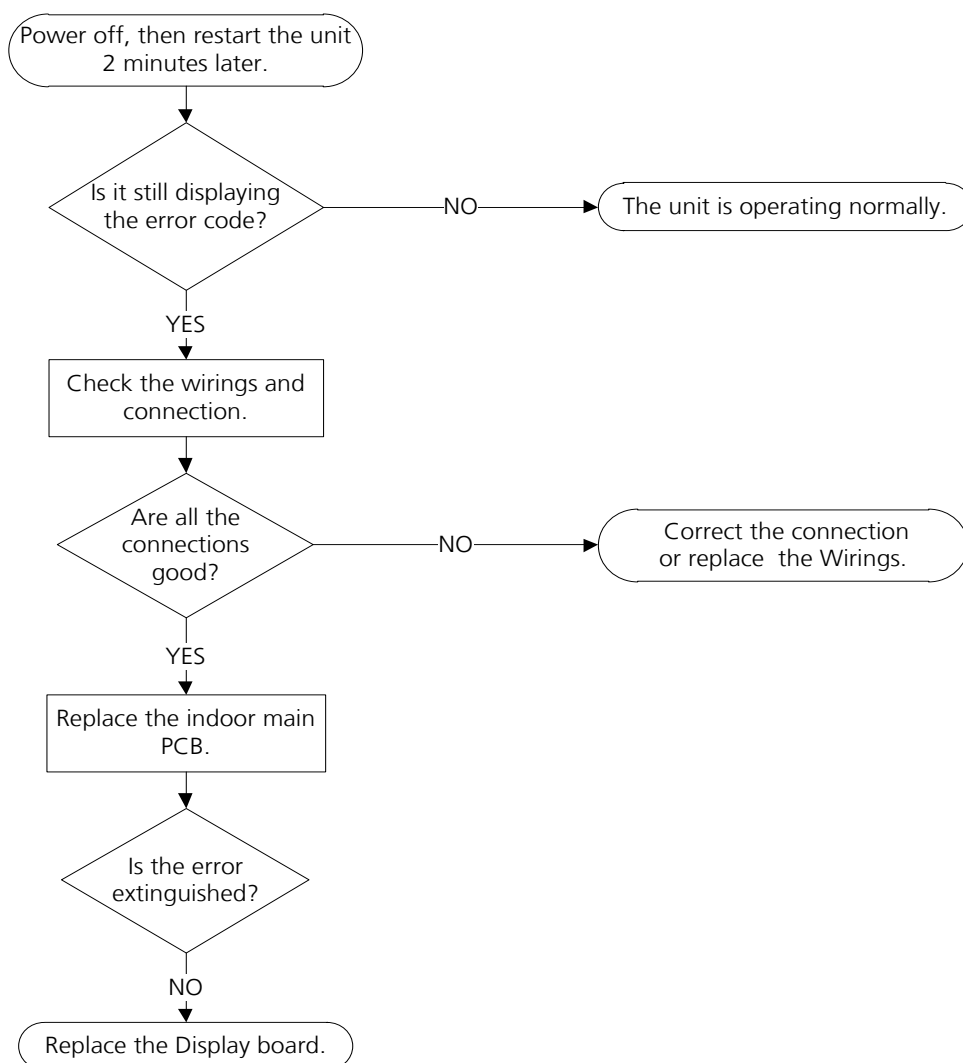

5.8 EC (Refrigerant Leakage Detection diagnosis and solution)

Description: Define the evaporator coil temp.T2 of the compressor just starts running as Tcool.

In the beginning 5 minutes after the compressor starts up, if $T2 < T_{cool} - 2^{\circ}\text{C}$ does not keep continuous 4 seconds and this situation happens 3 times, the display area will show "EC" and AC will turn off.

Recommended parts to prepare:

- Faulty T2 sensor
- Faulty compressor
- Faulty capacitor of compressor
- Faulty indoor PCB
- System problems, such as leakage or blockages
- Faulty capacitor of fan motor
- Faulty outdoor fan

Troubleshooting and repair:

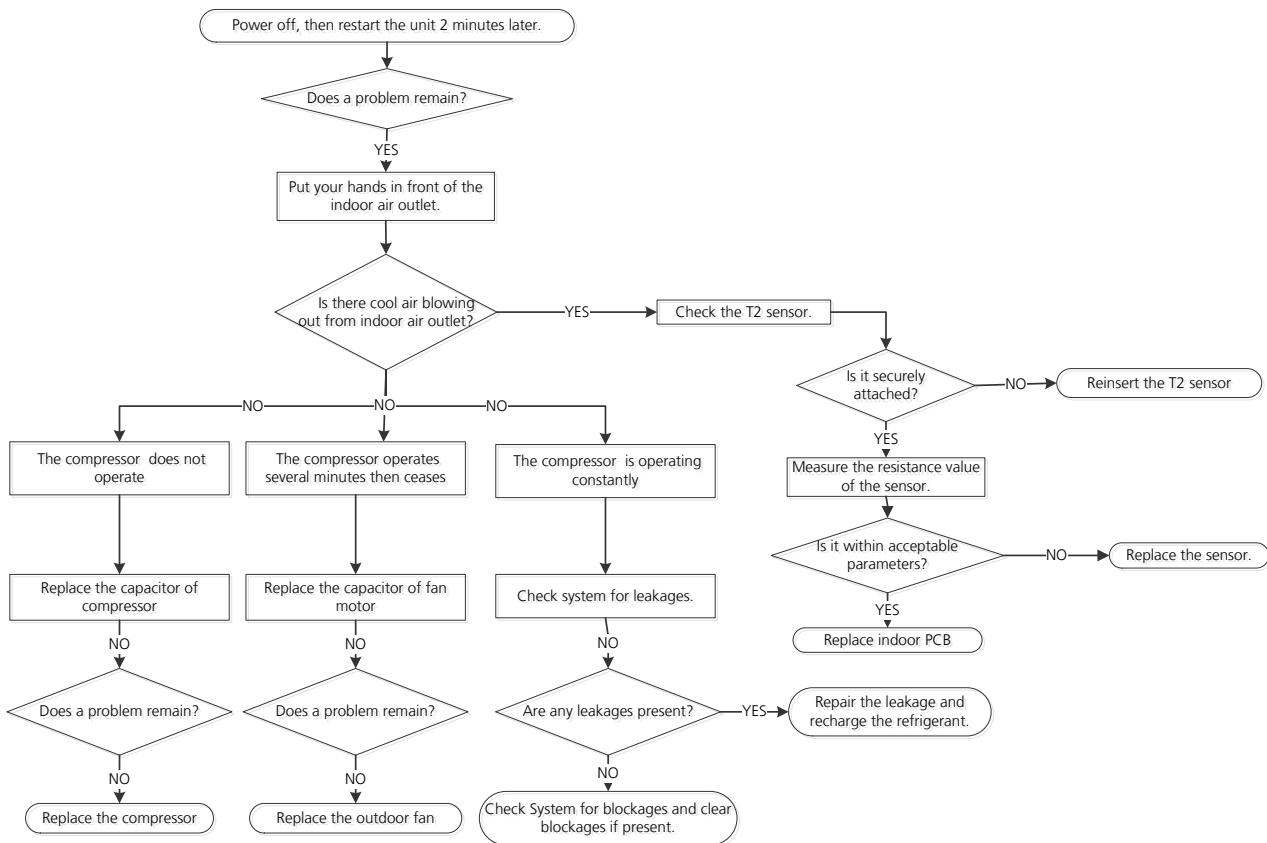

Appendix

Contents

- i) Temperature Sensor Resistance Value Table for T1, T2, T3, and T4 (°C – K)74
- ii) Pressure On Service Port75

i) Temperature Sensor Resistance Value Table for T1,T2,T3 and T4 (°C – K)

°C	°F	K Ohm	°C	°F	K Ohm	°C	°F	K Ohm	°C	°F	K Ohm
-20	-4	115.266	20	68	12.6431	60	140	2.35774	100	212	0.62973
-19	-2	108.146	21	70	12.0561	61	142	2.27249	101	214	0.61148
-18	0	101.517	22	72	11.5	62	144	2.19073	102	216	0.59386
-17	1	96.3423	23	73	10.9731	63	145	2.11241	103	217	0.57683
-16	3	89.5865	24	75	10.4736	64	147	2.03732	104	219	0.56038
-15	5	84.219	25	77	10	65	149	1.96532	105	221	0.54448
-14	7	79.311	26	79	9.55074	66	151	1.89627	106	223	0.52912
-13	9	74.536	27	81	9.12445	67	153	1.83003	107	225	0.51426
-12	10	70.1698	28	82	8.71983	68	154	1.76647	108	226	0.49989
-11	12	66.0898	29	84	8.33566	69	156	1.70547	109	228	0.486
-10	14	62.2756	30	86	7.97078	70	158	1.64691	110	230	0.47256
-9	16	58.7079	31	88	7.62411	71	160	1.59068	111	232	0.45957
-8	18	56.3694	32	90	7.29464	72	162	1.53668	112	234	0.44699
-7	19	52.2438	33	91	6.98142	73	163	1.48481	113	235	0.43482
-6	21	49.3161	34	93	6.68355	74	165	1.43498	114	237	0.42304
-5	23	46.5725	35	95	6.40021	75	167	1.38703	115	239	0.41164
-4	25	44	36	97	6.13059	76	169	1.34105	116	241	0.4006
-3	27	41.5878	37	99	5.87359	77	171	1.29078	117	243	0.38991
-2	28	39.8239	38	100	5.62961	78	172	1.25423	118	244	0.37956
-1	30	37.1988	39	102	5.39689	79	174	1.2133	119	246	0.36954
0	32	35.2024	40	104	5.17519	80	176	1.17393	120	248	0.35982
1	34	33.3269	41	106	4.96392	81	178	1.13604	121	250	0.35042
2	36	31.5635	42	108	4.76253	82	180	1.09958	122	252	0.3413
3	37	29.9058	43	109	4.5705	83	181	1.06448	123	253	0.33246
4	39	28.3459	44	111	4.38736	84	183	1.03069	124	255	0.3239
5	41	26.8778	45	113	4.21263	85	185	0.99815	125	257	0.31559
6	43	25.4954	46	115	4.04589	86	187	0.96681	126	259	0.30754
7	45	24.1932	47	117	3.88673	87	189	0.93662	127	261	0.29974
8	46	22.5662	48	118	3.73476	88	190	0.90753	128	262	0.29216
9	48	21.8094	49	120	3.58962	89	192	0.8795	129	264	0.28482
10	50	20.7184	50	122	3.45097	90	194	0.85248	130	266	0.2777
11	52	19.6891	51	124	3.31847	91	196	0.82643	131	268	0.27078
12	54	18.7177	52	126	3.19183	92	198	0.80132	132	270	0.26408
13	55	17.8005	53	127	3.07075	93	199	0.77709	133	271	0.25757
14	57	16.9341	54	129	2.95896	94	201	0.75373	134	273	0.25125
15	59	16.1156	55	131	2.84421	95	203	0.73119	135	275	0.24512
16	61	15.3418	56	133	2.73823	96	205	0.70944	136	277	0.23916
17	63	14.6181	57	135	2.63682	97	207	0.68844	137	279	0.23338
18	64	13.918	58	136	2.53973	98	208	0.66818	138	280	0.22776
19	66	13.2631	59	138	2.44677	99	210	0.64862	139	282	0.22231

ii) Pressure On Service Port(R410A)

Cooling chart:

°F(°C)	ODT		0(-17)	5(-15)	15 (9.44)	45 (7.22)	75 (23.89)	85 (29.44)	95 (35)	105 (40.56)	115 (46.11)	120 (48.89)
	IDT											
BAR	70/59		6.4	6.5	7.3	8.0	8.2	7.8	8.1	8.6	10.1	10.6
BAR	75/63		6.7	6.8	7.9	8.6	8.6	8.3	8.7	9.1	10.7	11.2
BAR	80/67		7.1	7.2	8.5	9.5	9.3	8.9	9.1	9.6	11.2	11.9
BAR	90/73		7.7	7.8	9.6	10.5	10.3	9.5	10.0	10.6	12.4	13.0

°F(°C)	ODT		0(-17)	5(-15)	15 (9.44)	45 (7.22)	75 (23.89)	85 (29.44)	95 (35)	105 (40.56)	115 (46.11)	120 (48.89)
	IDT											
PSI	70/59		93	94	106	116	119	113	117	125	147	154
PSI	75/63		97	99	115	125	124	120	126	132	155	162
PSI	80/67		103	104	123	138	135	129	132	140	162	173
PSI	90/73		112	113	139	152	149	138	145	154	180	189

°F(°C)	ODT		0(-17)	5(-15)	15 (9.44)	45 (7.22)	75 (23.89)	85 (29.44)	95 (35)	105 (40.56)	115 (46.11)	120 (48.89)
	IDT											
MPA	70/59		0.64	0.65	0.73	0.8	0.82	0.78	0.81	0.86	1.01	1.06
MPA	75/63		0.67	0.68	0.79	0.86	0.86	0.83	0.87	0.91	1.07	1.12
MPA	80/67		0.71	0.72	0.85	0.95	0.93	0.89	0.91	0.96	1.12	1.19
MPA	90/73		0.77	0.78	0.96	1.05	1.03	0.95	1	1.06	1.24	1.3

