

Exploded View - MGC3623E

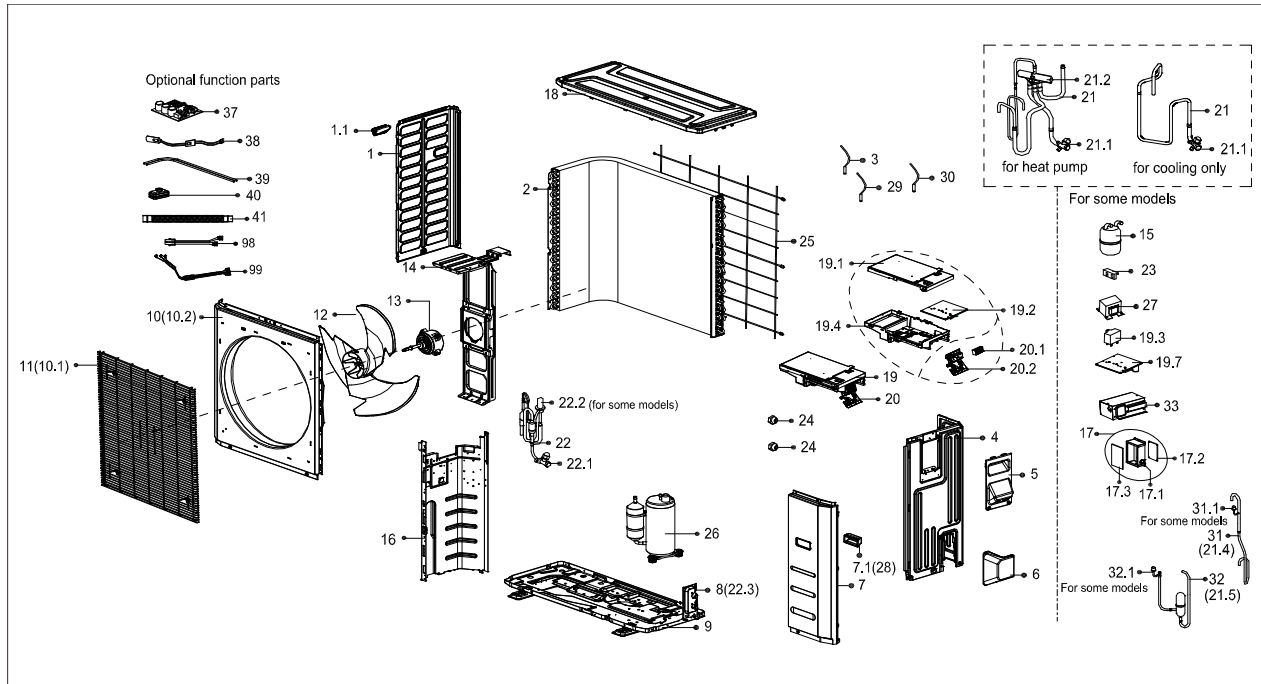

No.	Part No.	Part Name	Qty	Remark
1	12222000006665	Left side plate assembly of cabinet	1.0	
1.1	12100701000033	Small handle	1.0	
2	15822000008198	Condenser assembly	1.0	
3	11201007000136	Pipe temperature sensor	1.0	CGQ-WD/GW4100-L850-SMP3B-P800
4	12222000006664	Rear right clapboard assembly	1.0	
5	12222000011086	Big handle assembly	1.0	
6	12122200002695	Water collector	1.0	
7	12222500A00135	Front right clapboard assembly	1.0	
7.1	12100702000038	handle	1.0	
9	12222000004018	Chassis assembly	1.0	
10	12222000A01431	Front panel	1.0	
11	12222000007904	Air outlet grille	1.0	
12	12100105000084	Axial flow fan	1.0	ZL-560*139*12-3KN
13	11002015000247	Brushless DC Motor	1.0	ZKFN-120-8-2
14	12222000005162	Supporter subassembly of fan motor	1.0	
15	15500508000315	Accumulator cylinder	1.0	ZYT-12
16	12222200001158	Partition board assembly	1.0	
18	12222500000587	Top cover assembly	1.0	
19	17222000A53676	Electronic control box subassembly	1.0	
19.1	12122200002719	Electronic installing box subassembly	1.0	



Exploded View - MGC3623E

No.	Part No.	Part Name	Qty	Remark
19.2	17122000A13447	Outdoor main control board subassembly	1.0	US1-KFR105W/BP3N1W-350(PFC+311+767+ATF250+DWZL+DJR2).JD.FW.WXWKB.WK2
19.4	12122200002715	Electronic installing box subassembly	1.0	
19.7	17122000039750	Inverter module subassembly	1.0	
20	17222000014908	Terminal board subassembly	1.0	
20.1	17400401000037	Terminal	1.0	JXZ-AG6H-A
20.2	12222200001476	Terminal board	1.0	
21	15422000014492	4-way valve assembly	1.0	
21.1	15500204000025	Gas valve	1.0	DYF-C15N1
21.2	15500216000361	4-way valve	1.0	STF-02BN1
21.4	15122000021857	Suction pipe	1.0	
21.5	15122000011326	Discharge pipe	1.0	
22	15422000004954	Liquid valve assembly	1.0	
22.1	15500204000021	Gas valve	1.0	DYF-A28N
22.2	15500213000245	Electronic expansion valve	1.0	DPF(T01)2.4C-05(L=1500)
22.3	12222200002110	Valve plate	1.0	
24	15500406000003	Copper nut	1.0	TLM-D04
24	15500406000010	Copper nut	1.0	TLM-B02
25	12222000006604	Rear net	1.0	
26	11103020000319	DC Inverter rotary compressor	1.0	ATF250D22UMT
27	11201101000017	PFC inductor	1.0	HP-35A-500uH-FJ-B-01
29	11201007000157	Discharge temperature sensor	1.0	CGQ-WD/PQ3950-L500-SMP2B-G470
30	11201007000039	Room temperature sensor	1.0	CGQ-WD/SW4100-L850-SMP2-P650
31	15122000021854	Suction pipe assembly	1.0	
31.1	17400516000008	Pressure switch	1.0	
32	15122000011324	Discharge pipe assembly	1.0	
32.1	17400516000007	Pressure switch	1.0	
32.2	15500506000007	Muffler	1.0	
38	17402001000119	Crankcase electric heater	1.0	
39	17402002000043	Electric heating tube	1.0	
99	17401203000909	Compressor wire subassembly	1.0	
99	17401203000909	Compressor wire subassembly	1.0	