

Exploded View - MGC1213E-19

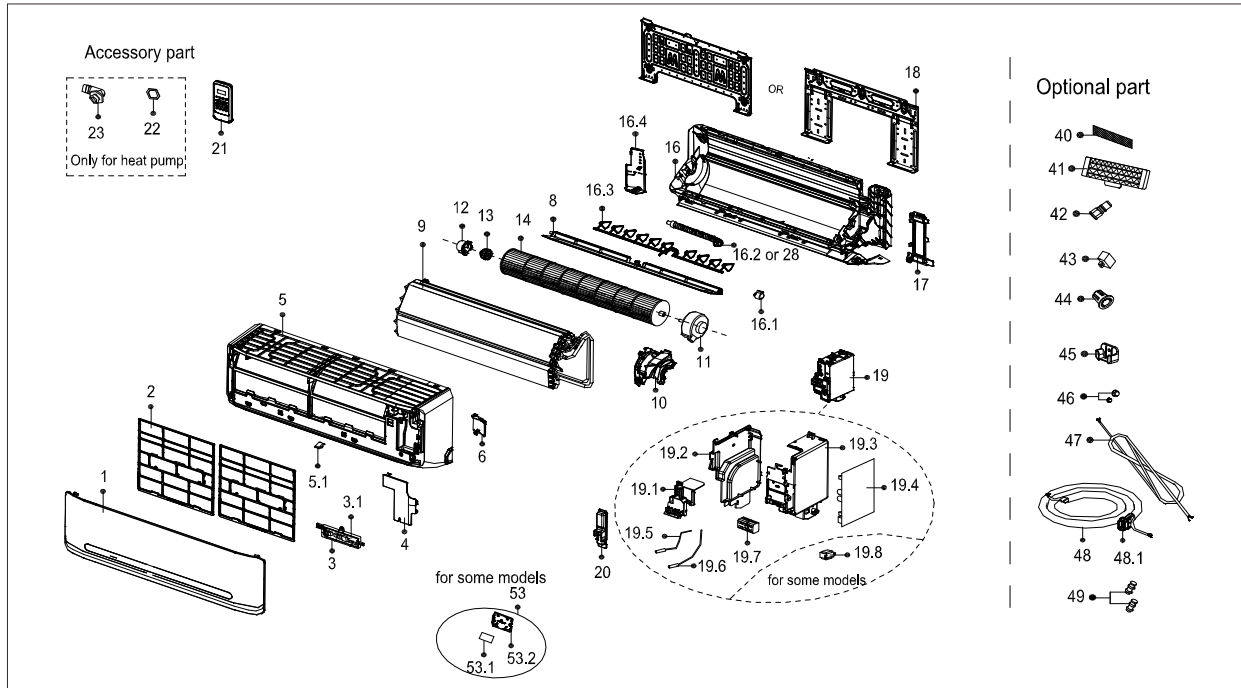

No.	Part No.	Part Name	Qty	Remark
1	12122000001521	Panel assembly	1.0	CE-KFR35G/N1Y-AB3.1(SY)
2	12100204000522	Filter filter subassembly	2.0	
3	17222000002878	Display box subassembly	1.0	
3.1	17122000006953	Display board subassembly	1.0	EU-KFR26G/N1Y-AB3.ZD.JGN.WXXS.XS2.1
4	12122000006755	Cover of electrical equipment	1.0	
5	12122000001726	Panel frame assembly	1.0	
5.1	12122000009477	Screw Cap	1.0	
6	12122000004587	Front cover of chassis(right)	1.0	
8	12122000005815	Horizontal louver assembly	1.0	
9	15822000008189	Evaporator assembly	1.0	
10	12122000005540	Fan motor cover	1.0	
11	11002012005527	Single phase asynchronous motor	1.0	YKFG-15-4-28-1
12	12122000000350	Bearing holder	1.0	
13	12622000000006	Bearing base	1.0	
14	12100102000044	Cross flow fan	1.0	GL-94*605-N
16	12122000011818	Chassis assembly	1.0	
16.1	11002010000143	Stepper motor	1.0	SM-24-19-16-8
16.3	12122000000038	Vertical vane subassembly	1.0	
16.4	12122000010098	Front cover of chassis(left)	1.0	
17	12122000012943	pipe clamp board	1.0	
18	12222000000018	Installation plate	1.0	



Exploded View - MGC1213E-19

No.	Part No.	Part Name	Qty	Remark
19	17222000011368	Electronic control box subassembly (Mid-and low-end)	1.0	
19.1	12122000004577	Electronic control box	1.0	
19.2	12122000004639	Left cover of electronic control box	1.0	
19.3	12122000004632	Right cover of electronic control box	1.0	
19.4	17122000021323	Main control board subassembly	1.0	US-KFR35G/BP2N1Y-AB.ZJD.JGN.WXNK.NK2.1
19.5	11201007003425	Room temperature sensor	1.0	CGQ-WD/SW4100-L500-XHBCP2BL-P450-HT1.0
19.6	11201007003447	Pipe Temperature Sensor	1.0	CGQ-WD/GW4100-L350-XACP2-P250
19.7	17400401000006	Terminal	1.0	JXZ-AD5Z(UL)-C(YF2004C)
20	12122000005020	Cover of electronic control box	1.0	
21	17317000001294	Remote controller	1.0	RG51F/EU1
28	12100501000032	Drain hose	1.0	
40	12100204000685	Air freshening filter	1.0	
46	15500406000016	Copper nut	1.0	TLM-A01
46	15500406000012	Copper nut	1.0	TLM-C03